

# Distribution Network Planning- Rural Un-electrified Areas



&

---

Planning for growing Urban  
agglomerates



---

# Distribution Network Planning- Rural Un-electrified Areas



# Distribution Network Planning- Rural Un-electrified Areas

---

Distribution Planning requires an analysis of various factors such as load growth, funds, ecological consideration, availability of land, etc. Distribution planning in a utility involves

- Ascertaining the time horizon for which it is envisaged
- Spelling out the specific activities required in the planning process, and
- Implementation of plans



# Time horizon for Planning

---

- Medium / long term planning is normally carried out as a part of a master plan for the distribution system as a whole. It normally considers a 5 to 15 years time frame and is based on the state/national as well as local load forecasts, industrialization plan and agricultural load forecasts.
- Estimating the funds required; and
- Arranging tie ups with the financial agencies for funds



# Principal Areas of Activity

---

- Load forecast
- Adequacy of back-up system
- Develop specific case studies and projects in a systematic manner
- Adjust capacity of 33 kV, 11 kV feeders, power transformers, distribution transformers and LT lines to meet the load at reasonable level of losses and least cost in an optimum manner
- Evaluate various alternatives



# Load forecast

---

- Existing Load Data Study
- Future Load Growth Study



# The steps involved in the load forecasting process are

---

- Data collection
- Data validation
- Selection of methodologies
- Development of assumptions
- Development of energy and demand forecasts; and



# Load forecast

---

- Comparison with the historical load growth data
- Power Factor / Reactive Load Study
- Economic impact study

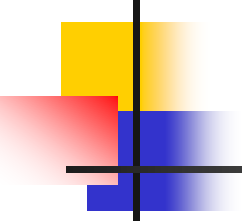
- 
- 
- FIRMING UP OF SCOPE OF WORKS AND THEIR PRIORITIZATION
  - PREPARATION OF COST ESTIMATES
  - PHASING OF WORKS AND THEIR COST
  - FINANCIAL ANALYSIS

# Planning for growing Urban agglomerates



---

# TASKS FOR PLANNING



➤ **MAPPING OF THE SYSTEM**

➤ **COLLECTION AND VALIDATION OF DATA**

➤ **ANALYSIS OF EXISTING SYSTEM**

➤ **ESTIMATION OF TECHNICAL LOSSES IN THE SYSTEM**

➤ **ADEQUACY OF BACK-UP SYSTEM**

➤ **LOAD FORECAST – GLOBAL AND SPATIALS**

➤ **ESTABLISHMENT OF PLANNING CRITERIA**

➤ **UPGRADATION OF NETWORK/EXPANSION**



## TASKS FOR LONG-TERM PLANNING (Contd)

---

- **CAPACITOR PLACEMENT**
- **LOAD BALANCING**
- **TRAINING OF PERSONNEL**
- **EVALUATION OF VARIOUS ALTERNATIVES FOR LEAST COST OPTIMAL SYSTEM**
- **FIRMING UP OF SCOPE OF WORKS AND THEIR PRIORITIZATION**
- **PREPARATION OF COST ESTIMATES**
- **PHASING OF WORKS AND THEIR COST**
- **FINANCIAL ANALYSIS**
- **PREPARATION OF LONG-TERM REPORT**

# ANTICIPATED ACHIEVEMENT

- 
- **REDUCTION OF TECHNICAL AND COMMERCIAL LOSSES**

---

  - **STRENGTHENING OF THE SYSTEM TO MEET THE FUTURE LOAD GROWTH**
  - **OPTIMISATION OF SYSTEM WITH LEAST COST**
  - **CUSTOMER SATISFACTION WITH IMPROVEMENT OF QUALITY AND RELIABILITY OF POWER SUPPLY**
  - **IMPROVEMENT IN METERING, BILLING AND REVENUE COLLECTION**
  - **DEVELOPMENT OF MANAGEMENT INFORMATION SYSTEM**
  - **IMPLEMENTATION OF IT FACILITIES**

# PLANNING PHILOSOPHY

THE APPROACH FOR PLANNING OF DISTRIBUTION SYSTEM SHOULD BE BASED ON THE FOLLOWING:-

---

- DELIVERING BULK SUPPLY OF ELECTRICITY AS NEAR TO THE LOAD CENTRES AS POSSIBLE.
- CONSUMERS AFFECTED DUE TO OUTAGE TO BE FEW IN THE AREA
- FORMATION OF RING CIRCUIT AND RADIAL CIRCUIT OR BOTH DEPENDING ON THE TECHNICAL AND ECONOMIC REQUIREMENT OF THE SYSTEM TO ENHANCE RELIABILITY OF POWER SUPPLY.

## PLANNING CRITERIA

**THE VOLTAGE VARIATIONS IN VARIOUS SYSTEM MUST NOT EXCEED THE FOLLOWING LIMITS AT THE FARTHEST END UNDER PEAK LOAD CONDITIONS AND NORMAL SYSTEM OPERATION REGIME.**

<b>ABOVE 33 KV</b>	<b>(-) 12.5% TO (+) 10%</b>
<b>UP TO 33 KV</b>	<b>(-) 9.0% TO (+) 6.0%</b>
<b>LOW VOLTAGE</b>	<b>(-) 6.0% TO (+) 6.0%</b>

**THE VOLTAGE VARIATIONS PERMISSIBLE ARE AS PER INDIAN REGULATIONS. THESE COULD BE AS PER THE REGULATIONS PREVALENT IN AFGHANISTAN**

# PLANNING CRITERIA



**IN CASE IT IS DIFFICULT TO ACHIEVE THE DESIRED VOLTAGE ESPECIALLY IN RURAL AREAS, THEN 11/0.433 KV DISTRIBUTION TRANSFORMERS ( IN PLACE OF NORMAL 11/0.4 KV DT'S) MAY BE USED IN THESE AREAS.**

**ADEQUATE POWER SUPPLY AT NORMAL VOLTAGE SHALL BE AVAILABLE AT MAIN GRID SUB-STATIONS TO MEET THE SYSTEM DEMAND .**

**THE TRANSFORMATION CAPACITY AT THE GRID SUB-STATIONS SHALL BE SUCH THAT THE SYSTEM DEMAND SHALL BE MET EVEN WITH THE OUTAGE OF THE LARGEST CAPACITY TRANSFORMER.**

## PLANNING CRITERIA(CONTD)

EVERY PRIMARY RECEIVING SUB-STATIONN MAY BE PROVIDED WITH AT LEAST TWO TRANSFORMERS HAVING EITHER SUFFICIENT CYCLIC LOADING CAPACITY TO SUPPLY THE SUB-STATION MAXIMUM DEMAND OR SUFFICIENT

11 KV SYSTEM INTER-CONNECTION TO ENABLE THE MAXIMUM DEMAND IN THE AREA TO BE MET IN THE EVENT OF OUTAGE OF SINGLE LARGEST CAPACITY TRANSFORMER.

33/11 KV SUBSTATION SHOULD HAVE AT LEAST TWO INCOMING FEEDERS FROM TWO DIFFERENT SOURCES FROM RELIABILITY CONSIDERATIONS.

## PLANNING CRITERIA(Contd)

THE SITING OF PRIMARY SUBSTATION I.E. 33/11 KV SUBSTATION SHOULD BE ON THE BASIS OF SPATIAL LOAD FORECAST, DEMOGRAPHIC FACTORS, SPACE AVAILABILITY, RIGHT OF WAY CONSIDERATIONS, EXISTING NETWORK CONFIGURATION ETC

THE PREFERRED TRANSFORMER CAPACITIES FOR PRIMARY SUB-STATIONS (I.E. 66/11 KV OR 33/11 KV) SHOULD BE OF 6.3, 8, 10, 16 MVA FOR URBAN AREAS AND 1, 1.6, 3.15, 5 MVA FOR RURAL AREAS.

## PLANNING CRITERIA(Contd)

### RATING OF THE DISTRIBUTION TRANSFORMERS

25, 50, 63, 100, 250, 315, 400, 500 AND 630 KVA.

THE HIGHER CAPACITY (i.e. LARGER THAN 250 KVA) SHALL BE USED FOR CONCENTRATED LOADS OR AREA WITH HIGH LOAD DENSITY AND LOWER CAPACITY (LESS THAN 100 KVA) MAY BE USED FOR RURAL AREAS. IN HIGH RISE BUILDING HAVING CONCENTRATED LOADS. HIGHER CAPACITY DISTRIBUTION TRANSFORMERS SUCH AS 1000 KVA MAY BE USED.

## PLANNING CRITERIA(Contd)

33/0.415 KV DISTRIBUTION TRANSFORMERS OF APPROPRIATE RATING-630 KVA, 1000 KVA, 1600 KVA, 2000 KVA , MAY ALSO BE USED BASED ON TECHNO-ECONOMIC CONSIDERATIONS.

LOWER RATINGS COULD BE USED FOR RURAL AREAS/ FAR FLUNG URBAN AREAS.

STANDARDISATION OF RATINGS WOULD HELP IN ACHIEVING REDUCTION IN INVENTORY FOR PURPOSES OF PROCUREMENT AND MAINTENANCE AND REDUCTION IN PRICE ON ACCOUNT OF BULK PURCHASE.

## PLANNING CRITERIA(CONTD)

THE 11 KV FEEDERS SHALL GENERALLY NOT BE LONG UNDER NORMAL CONDITIONS AND SHALL AS FAR AS POSSIBLE FEED ONLY LOCAL AREAS.

THE 11 KV FEEDERS SHALL BE SO PLANNED THAT WHEREVER THE SIZE OF THE CONDUCTOR IS ADEQUATE OR THE VOLTAGE DROP EXCEEDS THE PRESCRIBED LIMIT, THE EXISTING CONDUCTORS SHALL EITHER BE REPLACED BY HIGHER SIZE CONDUCTOR OR LOAD ON THE FEEDER SHALL BE REDUCED BY ADDITION OF NEW FEEDERS. EXISTING LINES SHOULD BE UTILIZED TO THE MAXIMUM EXTENT.

# PLANNING CRITERIA(CONTD)

➤POWER FACTOR PREFERABLY BE NOT LESS THAN 0.95 LAG AT 11KV LEVEL.

➤THE LEVEL OF SECURITY OF SUPPLY TO BE PROVIDED IS A MATTER OF SUBJECTIVE JUDGMENT.HIGHER LEVEL MEANS HIGHER COST. THE HIGHEST DEGREE OF SECURITY IS OBTAINED WHEN A SUB-TRANSMISSION SYSTEM IS OPERATED IN CLOSED RING BUT THIS METHOD REQUIRES AN EXPENSIVE PROTECTION SYSTEM. OPERATION IS MORE COMPLICATED AND THIS SYSTEM SHOULD BE RESTRICTED TO VERY DENSELY LOADED CITY CENTERS OR VIP AREAS WHERE SECURITY OF SUPPLY IS ESSENTIAL. MORE COMMON ARRANGEMENT REQUIRING LESS OF INVESTMENT WOULD BE AN OPEN RING SYSTEM.

# PLANNING CRITERIA(Contd)

**SUB-STATION LAYOUT : BEFORE DECIDING THE RATINGS OF THE EQUIPMENT IN A SUB- STATION IT IS NECESSARY TO PREPARE A SCHEMATIC/LAY OUT DIAGRAM OF THE SUBSTATION.**

**SINGLE BUS BAR,. SINGLE BUS BAR WITH BUS SECTIONALIZER, DOUBLE BUSBAR, DOUBLE BUS BAR WITH DOUBLE BREAKER SCHEME AND MESH SCHEME ARE THE VARIOUS TYPES OF LAYOUTS BEING ADOPTED. A LAYOUT WHICH IS MOST ECONOMICAL, SATISFIES TECHNICAL REQUIREMENTS AS PER ACTUAL SITE CONDITIONS MAY BE ADOPTED. GENERALLY 33/11 KV SUB-STATION WITH SINGLE BUS BAR AND A SECTIONALISER IN BETWEEN ON THE 33 KV AS WELL AS 11 KV SIDES IS BEING ADOPTED.**

# PLANNING CRITERIA(Contd)

## LAYOUT & BUS BAR ARRANGEMENTS

### **FACTORS AFFECTING LAYOUT AND BUS BAR ARRANGEMENTS**

- **SYSTEM VOLTAGE**
- **POSITION OF SUB-STATION IN THE SYSTEM**
- **FLEXIBILITY**
- **RELIABILITY OF SUPPLY**
- **COST**
- **TECHNICAL CONSIDERATION**
- **SIMPLICITY**
- **EASE IN MAINTENANCE WITHOUT INTERRUPTION OF SUPPLY**
- **ENSURING SAFETY OF PERSONNELS**
- **ALTERNATIVE ARRANGEMENTS**
- **EXPANSION OF AUGMENTATION**

# PLANNING CRITERIA(Contd)

## FACTOR EFFECTING FORM OF LAYOUT

➤ **AVAILABLE LAND AREA**

➤ **SITE AND CLIMATIC CONDITIONS**

➤ **PLANNING AUTHORITY REQUIREMENTS**

➤ **AESTHETIC CONSIDERATIONS**

➤ **DIRECTION OF O/H LINE ENTRIES**

➤ **POSITION OF TERMINAL TOWERS**

➤ **LOCATION OF TRANSFORMERS AND REACTORS**

➤ **TRANSPORTATION OF MATERIAL AND ACCESS FACILITIES**

➤ **DISTANCE BETWEEN VARIOUS EQUIPMENTS**

➤ **PHASE SEGREGATION DISTANCE**

➤ **PHASE TO GROUND SEGREGATION DISTANCE**

# PLANNING CRITERIA(Contd)

## STEPS FOR EVOLVING SUB-STATION LAYOUT

- **ESTABLISH IMPORTANT ELECTRICAL PARAMETERS SUCH AS**
  - ✓ **VOLTAGE AND BASIC INSULATION LEVEL OR SWITCHING SURGE LEVEL**
  - ✓ **BUS BAR SYSTEM DIAGRAM, THE NO OF CIRCUITS SYSTEM VOLTAGE, TYPE OF FEEDER,**
  - ✓ **FUTURE EXTENSIONS ETC**
- **CONTINUOUS CURRENT RATING**
- **NEUTRAL EARTHING EQUIPMENT**
- **METHOD OF CONNECTION O/H OR U/G**
- **DETAILS OF LIGHTNING PROTECTION EQUIPMENT**
- **PROTECTION EQUIPMENT**
- **FACILITY OF MAINTENANCE WITHOUT INTERRUPTION OF SUPPLY**

# PLANNING CRITERIA(Contd)

## LIST OF DRAWINGS

- **SITE PLAN AND VICINITY MAP**
- **SINGLE LINE DIAGRAM**
- **SWITCH YARD LAY OUT PLAN , ELEVATION AND SECTIONAL VIEWS**
- **EQUIPMENT LAY OUTS AND SECTIONAL VIEWS**
- **CONTROL ROOM LAY OUT**
- **PLAN SHOWING TRANSFORMER RAILTRACK AND ROADS**
- **REPAIR BAY LAY OUT**
- **SECONDARY CONNECTION DIAGRAMS**
- **CABLE LAY OUT**
- **AC AND DC SYSTEM LAYOUT**
- **SCHEMNEATIC DIAGRAMS OF EQUIPMENTS SHOWING b  
INTERCONNECTION**
- **PLAN OF ILLUMINATION SYSTEM**
- **MATERIAL SCHEDULES**
- **CONSTRUCTION PERT OR BAR CHART**

# PLANNING CRITERIA(Contd)

## SINGLE BUS BAR ARRANGEMENTS

### DISADVANTAGES:

- **INTERRUPTION FOR MAINTENANCE**
- **EXTENSION NOT POSSIBLE WITHOUT SHUT DOWN**

### ADVANTAGES:

- **CONVENIENT TO OPERATE**
- **NOT VERY POPULAR FOR 33 KV AND ABOVE**

**INDOOR 11 KV SWITCHGEAR HAVE THIS ARRANGEMENT**

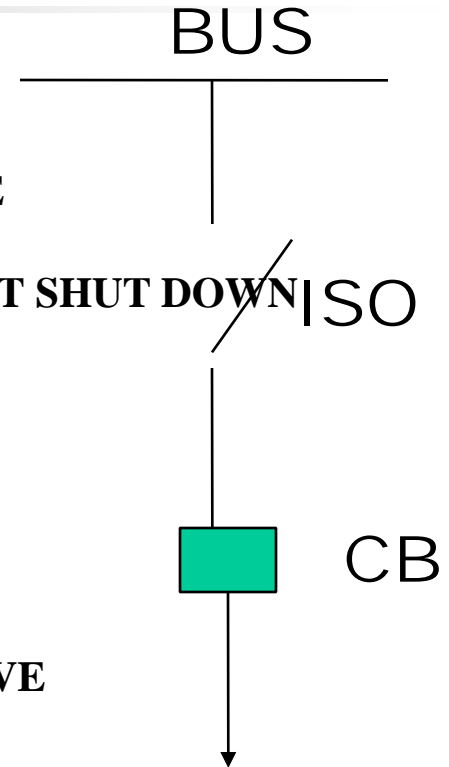

# SINGLE BUS BAR WITH BUS SECTIONALISER

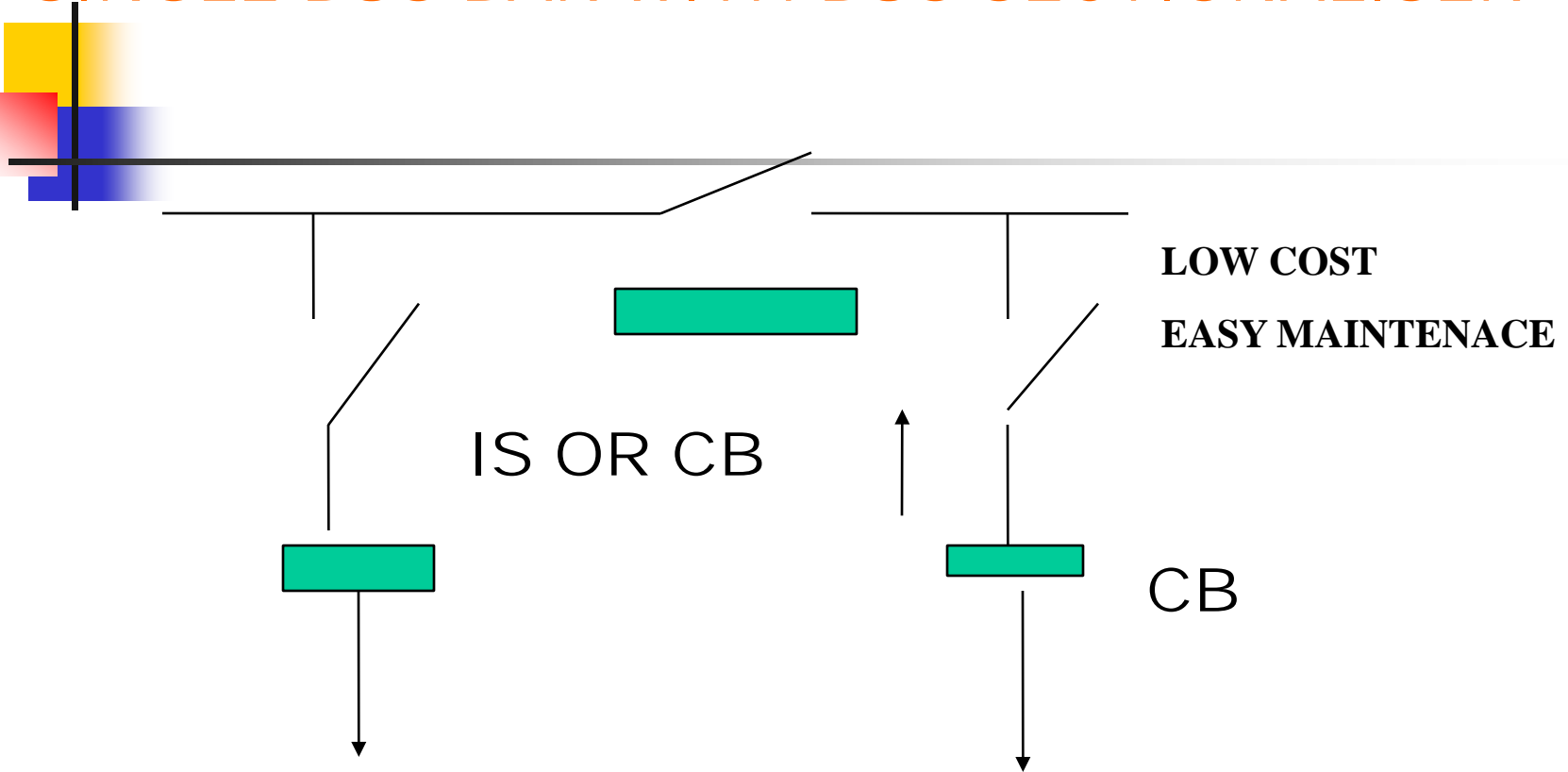

## DISADVANTAGES :

➤ **IN CASE OF BUS FAULT OR BUS BAR ISOLATOR FAULT OR MAINTENANCE ASSOCIATED SYSTEM IS LOST**

➤ **IN CASE OF MAINTENANCE OF TRANSFORMER ,THE ASSOCIATED TRANSFORMER HAS ALSO TO BE SHUT DOWN**

# DOUBLE BUS BAR SCHEME

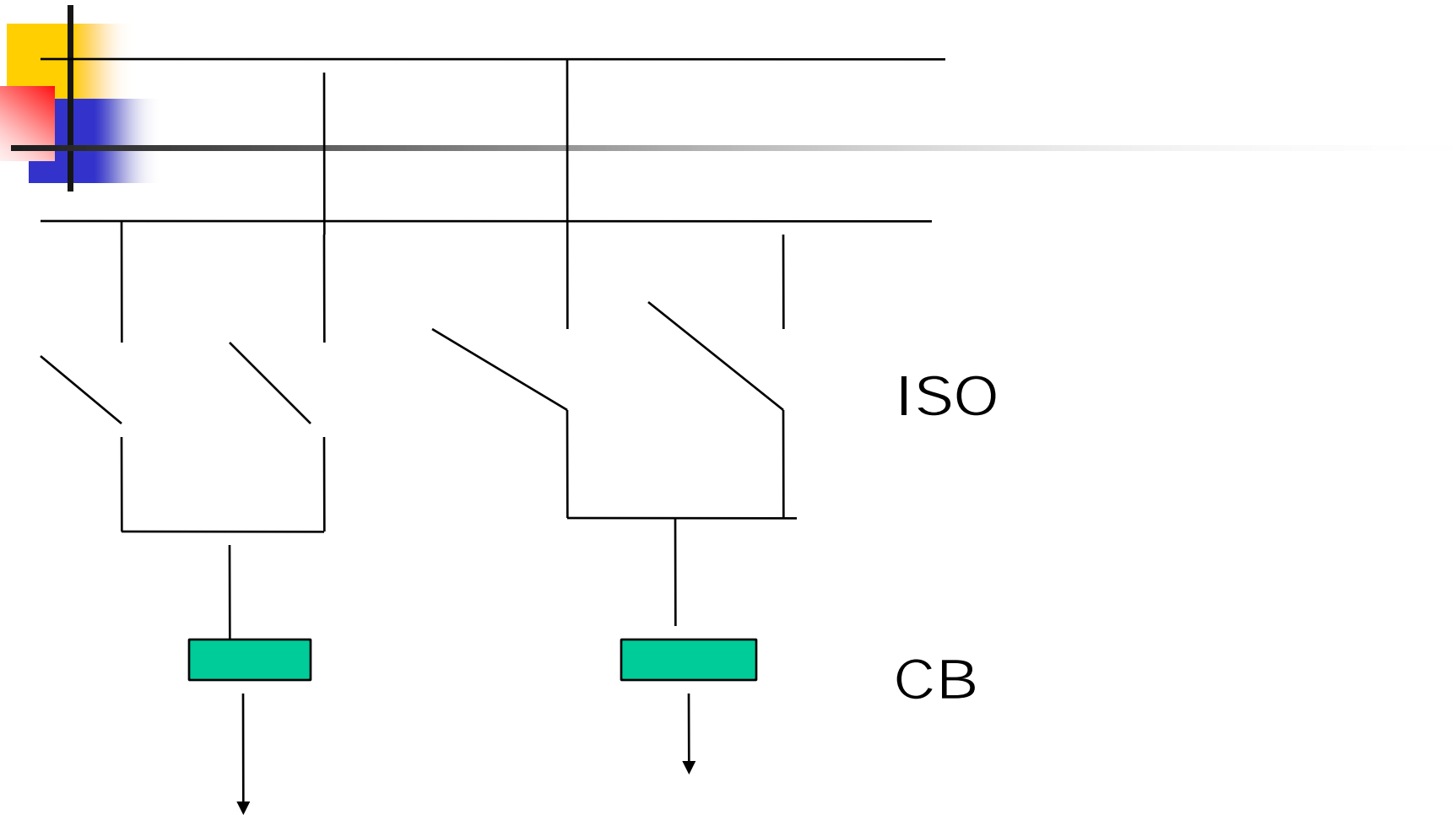

ANY FEEDER CAN BE CONNECTED TO ANY BUS. FLEXIBLE ENOUGH. BUS MAINTENANCE IS EASY

# BREAKER AND HALF SCHEME

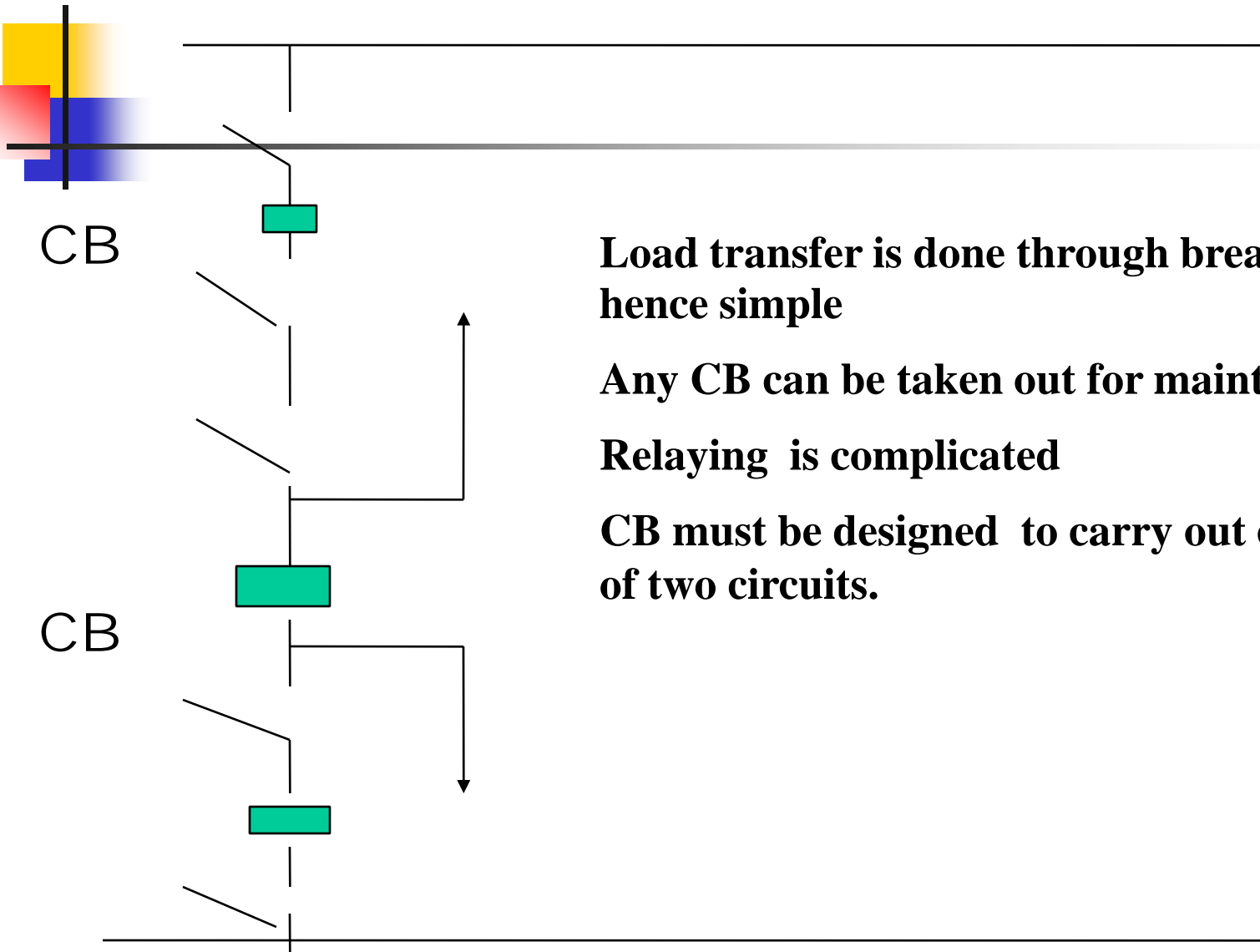

**Load transfer is done through breaker and hence simple**

**Any CB can be taken out for maintenance**

**Relaying is complicated**

**CB must be designed to carry out currents of two circuits.**

# MAIN AND TRANSFER BUS SCHEME

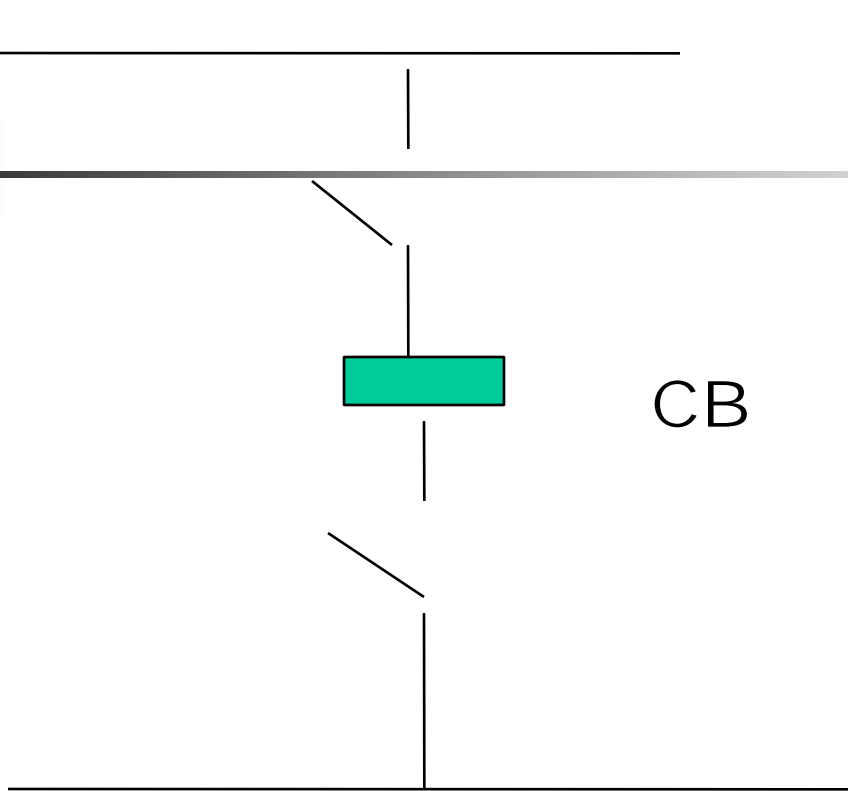

**Maintenance of any feeder at a time is possible without main bus or feeder shut down.**

**As in case of single bus bar arrangement , in case of fault on the main bus bar or the associated isolator, there is complete shut down of the station.**

# PLANNING CRITERIA(Contd)

## RING BUS FOR 11 KV

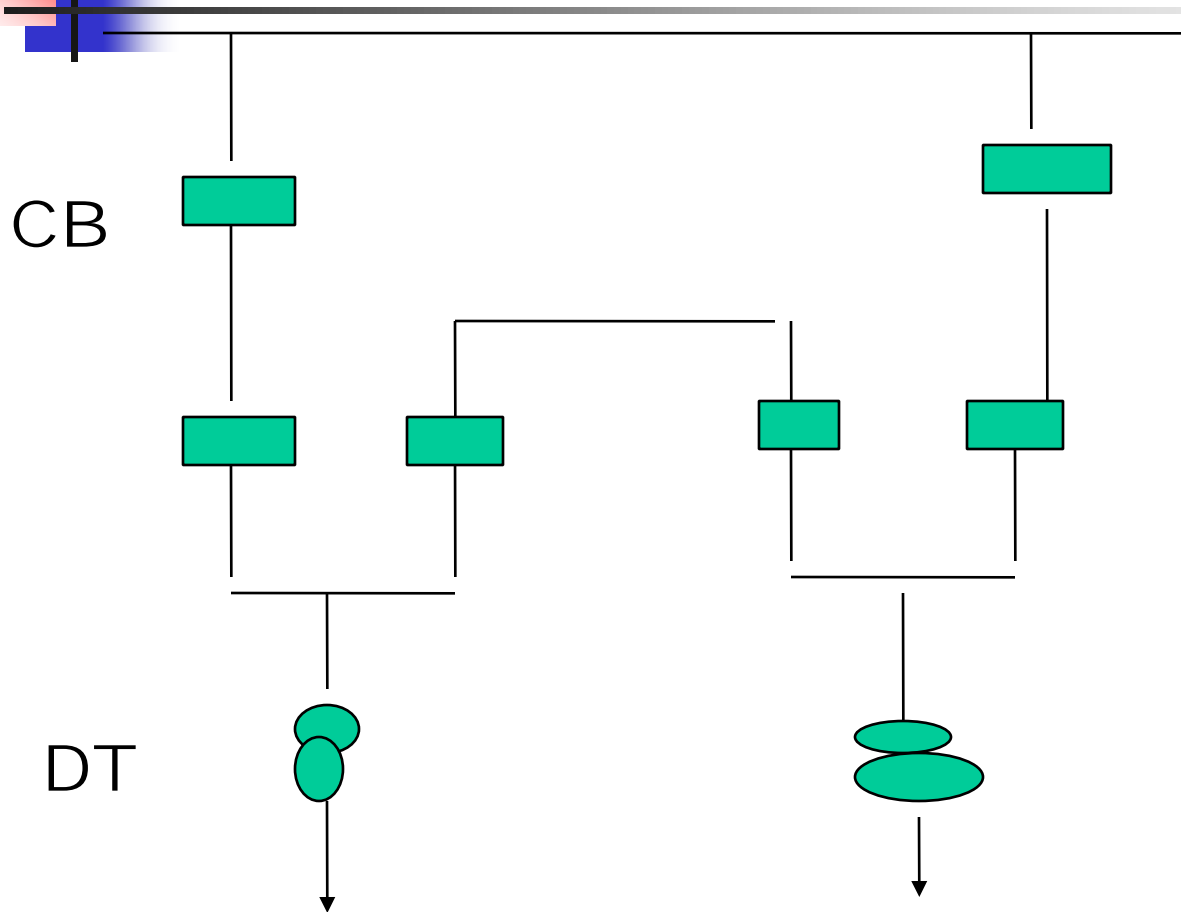

# PLANNING CRITERIA(Contd)

## RADIAL ARRANGEMENT

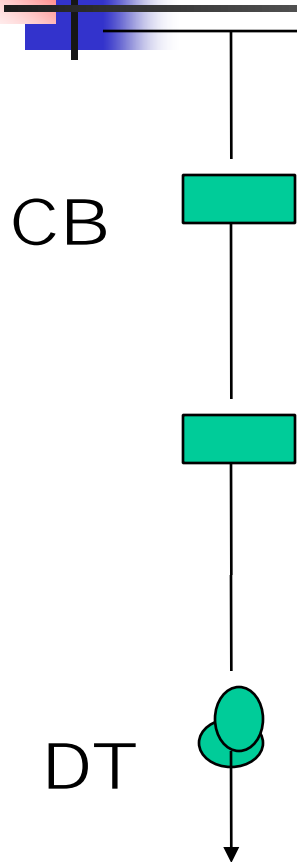

**SUITABLE FOR LIGHT AND MEDIUM DENSITY SYSTEMS**

**RELIABILITY IS NOT A PRIME CONSIDERATION**

# PLANNING CRITERIA(CONT'D)

MOST POWER UTILITIES USE ACSR ON ACCOUNT OF PRICE CONSIDERATIONS ALTHOUGH AAAC CONDUCTORS ARE LIGHTER IN WEIGHT, HAVE A LONGER LIFE ON ACCOUNT OF HIGHER RESISTANCE TO CORROSION .

<b>RATED SYSTEM VOLTAGE</b>	<b>CONDUCTOR TYPE</b>
33 KV	PANTHER, WOLF, DOG OR EQUIVALENT AAAC. XLPE CABLES OF 150, 185, 240,300 AND 400 SQ.MM.
11 KV	DOG,RACOON,RABBIT OR EQUIVALENT AAAC AERIAL BUNCHED CABLES (ABC)3-CORE XLPE CABLES OF SIZES 120,150, 185, 240 & 300 SQ.MM.

## PLANNING CRITERIA(CONT'D)

**LT DOG, RACCOON, RABBIT, WEASEL**

**AAC ANT, GRASSHOPPER, WASP**

**OR EQUIVALENT AAAC.**

**EQUIVALENT AERIAL BUNCHED CABLES (ABC)3<sup>1</sup>/<sub>2</sub>  
CORE OR 4-CORE PVC CABLES OF 95, 120, 150, 185, 240  
& 300 SQ.MM.**

## PLANNING CRITERIA(Contd)

**MAXIMUM FAULT LEVELS: THE THREE PHASE FAULT LEVELS MAY NOT EXCEED THE FOLLOWING EXCEPT WHERE THE SYSTEM IS NEARER TO THE GENERATING SOURCE WHERE ACTUAL SHORT CIRCUIT VALUE MAY BE USED TO DECIDE SWITCHGEAR SPECIFICATIONS:**

**33 KV SYSTEMS**

**750 MVA**

**11 KV SYSTEM**

**350MVA(URBAN AREA)**

**250 MVA (RURAL AREA)**

# PLANNING CRITERIA(Contd)

## AUGMENTATION:

- ❖ STUDY THE ENTIRE SYSTEM FROM 33KV TO THE LT CONSUMER, ESTIMATE THE EXISTING LOSSES.
- ❖ REMOVE THE ENTIRE OPEN LT SYSTEM AND REPLACE BY LT LESS SYSTEM WHICH INCLUDES
  - ❖ REPLACE LT LINES BY 11 KV LINES ON SAME POLES.
  - ❖ ERECT 10, 16, 25 KVA 11 KV/415 V 1PHASE / 3PHASE TRANSFORMERS ON EACH POLE.
  - ❖ SUPPLY POWER TO 8 TO 10 CONSUMERS FROM THESE TRANSFORMERS THROUGH LT AERIAL BUNCHED CABLE.
  - ❖ WHEREVER SPACE CONSTRAINT, REPLACE LT LINE WITH 11KV ABC. **AND**
  - ❖ SUPPLY THROUGH SMALL TRANSFORMER.

# PLANNING CRITERIA(Contd)

**ABSOLUTELY NO SPACE, SUPPLY THROUGH AERIAL BUNCHED CABLE TO A GROUP OF 10 TO 12 CONSUMERS.**

**HIGHLY CONGESTED & HIGHLY THEFT PRONE AREA:**

**INSTALL 100 KVA TRANSFORMERS AT THE CORNER OF STREET THROUGH PROTECTION RATED TO 1.5 TIMES THE LEGALLY CONNECTED LOAD. NEIGHBOUR WILL FORCE OTHER TO GET LEGAL CONNECTION.**

**SUPPLY ALL INDUSTRIES ALSO ON 11 KV**

**POLE MOUNTED 63/100 KVA 11 KV/415 V TRANSFORMERS.**

**EACH TRANSFORMER FEEDS 4 TO 5 INDUSTRIES THROUGH GROUP METERING DEPENDING ON CONNECTED LOAD. 11 KV CONSUMERS REMAIN HT CONSUMERS.**

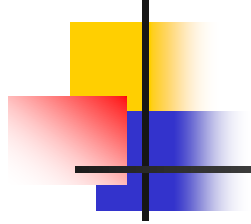

---

*Thank You !*