



USAID
FROM THE AMERICAN PEOPLE

SARI / Energy

***Refresher course on Electrical fundamentals
(Basics of A.C. Circuits)***

by B.M.Vyas

A specifically designed programme for

Da Afghanistan Breshna Sherkat (DABS)
Afghanistan



USAID
FROM THE AMERICAN PEOPLE

SARI / Energy

Areas Covered Under this Module

- 1. Sinusoidal AC waveform**
- 2. Instantaneous current and Voltage**
- 3. Series RL circuit**
- 4. Types of power and energy in ac circuits, power triangle**
- 5. Vector diagrams as a analysis tool**
- 6. Power flow principles**

Components of A.C. Circuits

- Generation, transmission and distribution, all deal with sinusoidal voltages and currents
- All loads may be represented as series/ parallel combination of *resistance, inductance and capacitance*.
- We want to *obtain the steady state performance* of the circuit.
- Simplest method of calculation is to use notations of *Phasor Algebra*.



VOLTAGE / CURRENT SINE WAVE

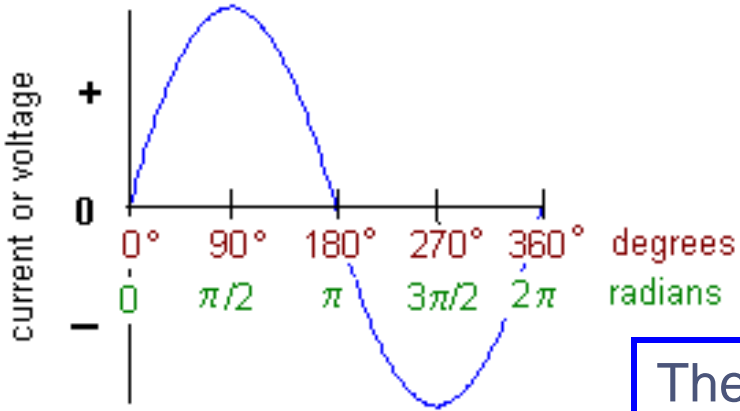

The equation of instantaneous value is

$$v = V_m \sin\Phi$$

$$v = V_m \sin \omega t$$

v = instantaneous voltage
 V_m = maximum /peak voltage
 Φ = angle in degrees or radians
 $\omega = 2 \pi f$

What about ac sine current waveform?



Phase Shift

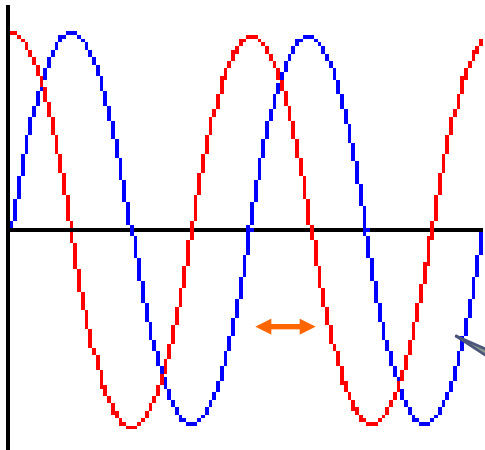

Red is Leading

This gap gives the amount of phase shift

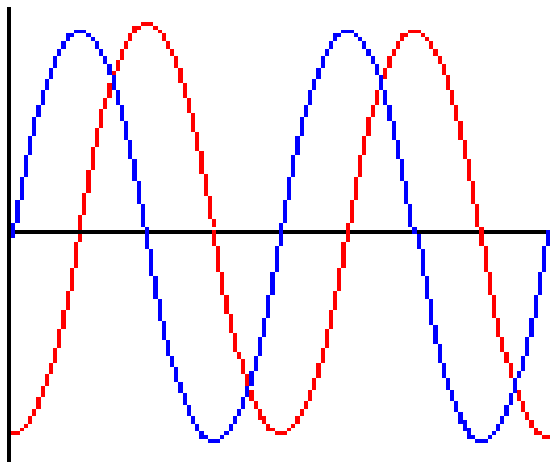

Red is lagging

Phase Shift of "B with respect to A"?

Case 1

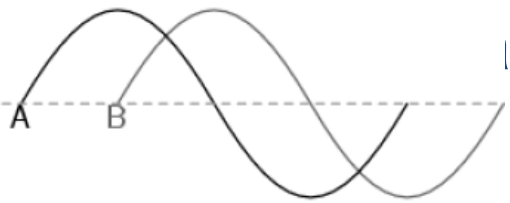

Case 2

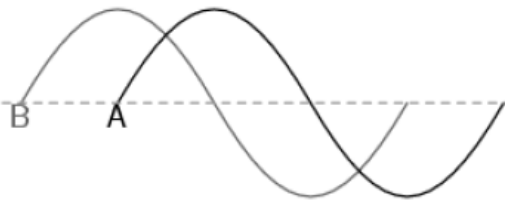

Case 3

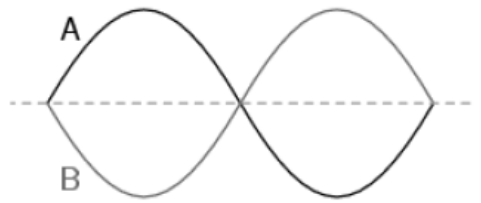

Case 4

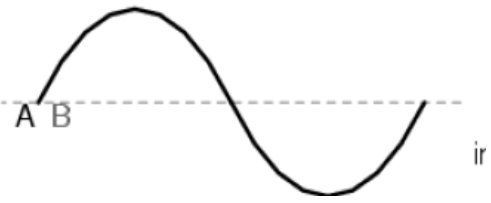

The RMS value of an alternating current is given by the steady (DC) Current which when flowing through a given circuit for a given time Produce the same heat as produced by the alternating current when Flowing through same circuit for the same duration.

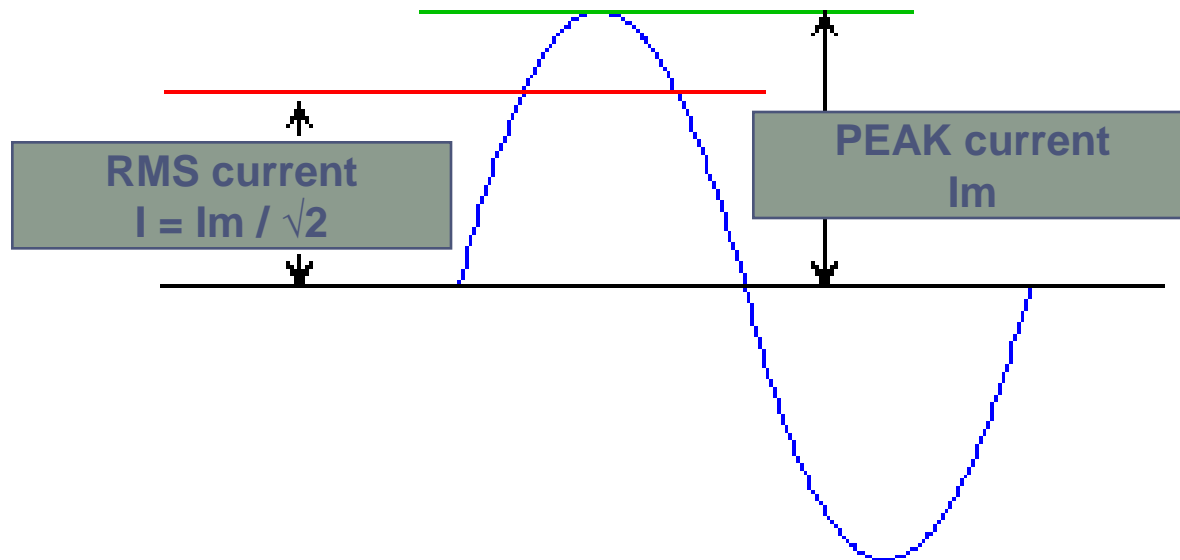

AVERAGE CURRENT

The average value of an AC is expressed by that steady current (DC) Which transfers across any circuit, the same charge as is transferred by That of AC

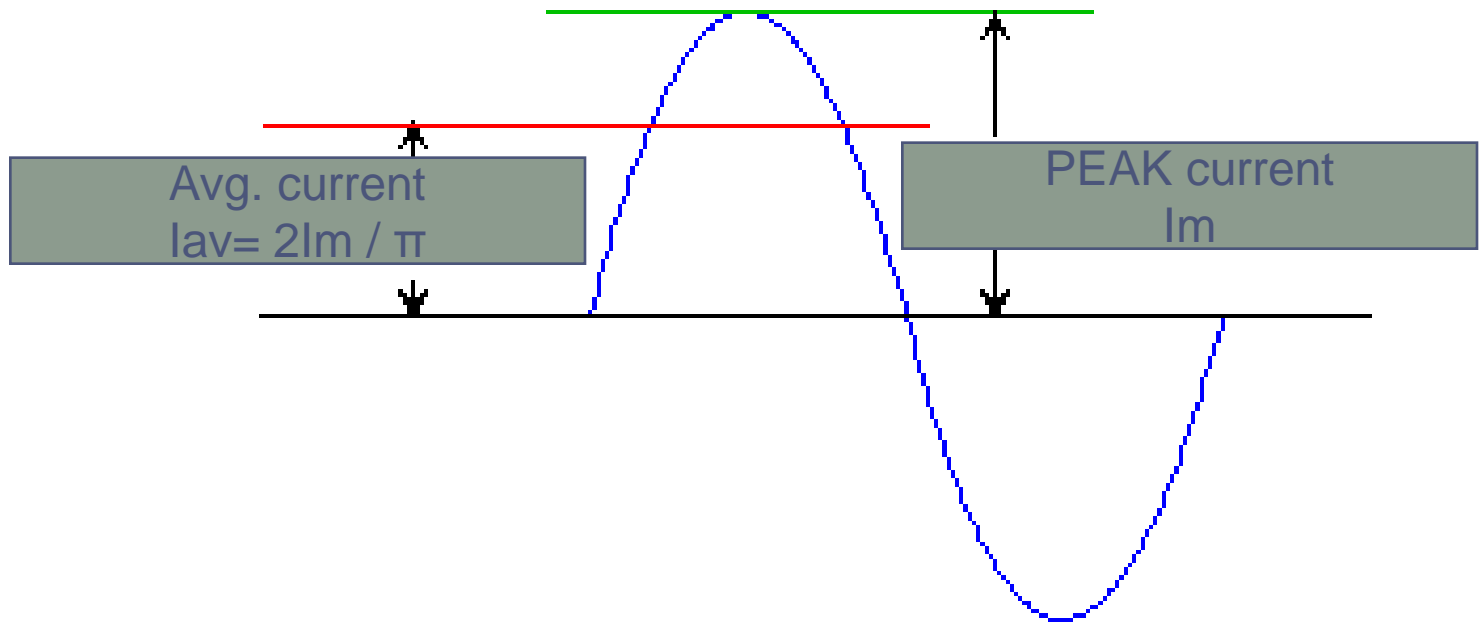

Scalar

- A scalar is a quantity with magnitude only. It has no direction.
- Example of scalar quantities are
 - Length
 - Area
 - Volume
 - Speed
 - Mass
 - Energy
 - Work
 - Power
 - Temperature
 - Pressure

Vector or phasor

A vector quantity has both magnitude and direction.

E.g.
Displacement, Velocity, force, acceleration etc.

Vector Components components are scalars

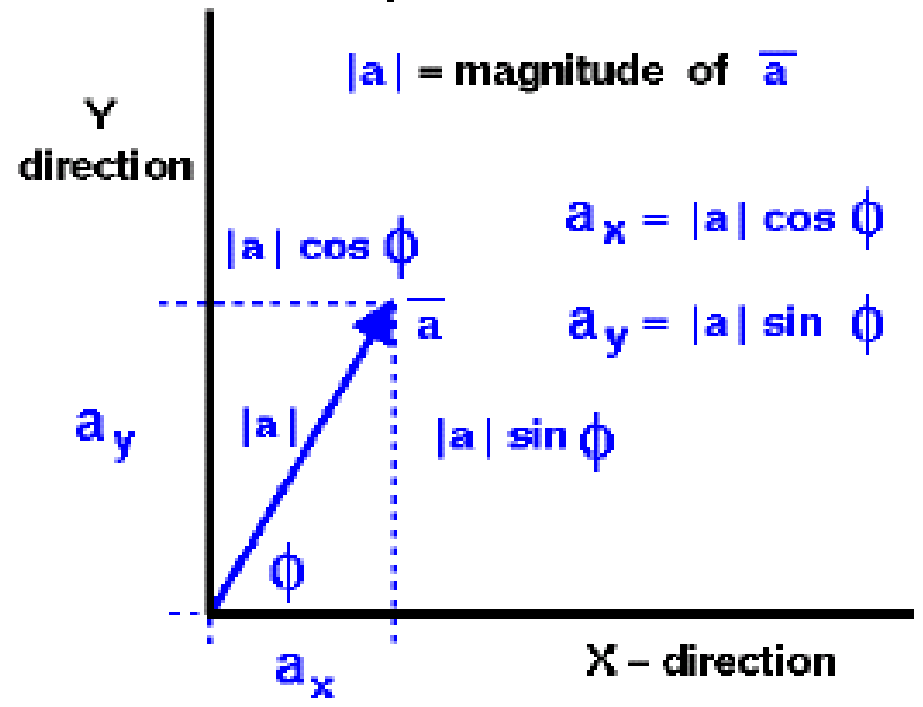



Addition & Subtraction of two Vectors

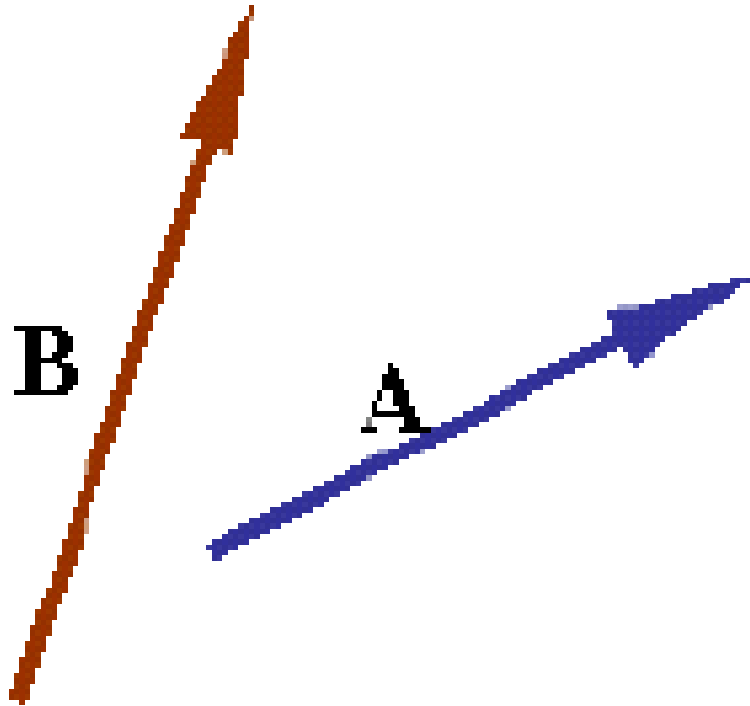

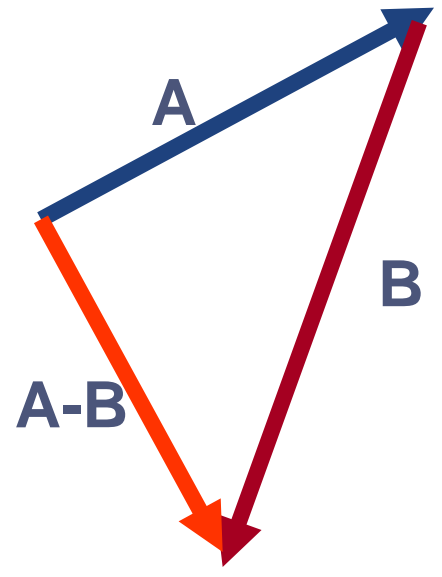
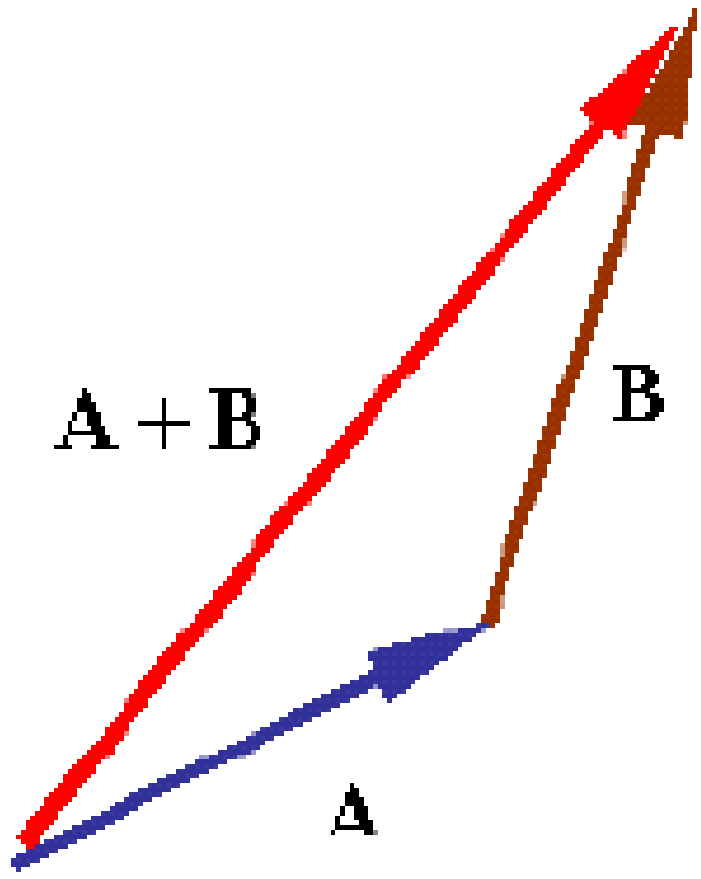

PURE RESISTIVE CIRCUIT

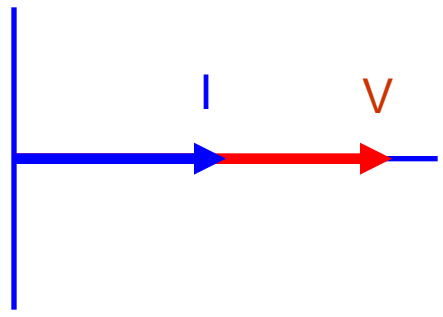
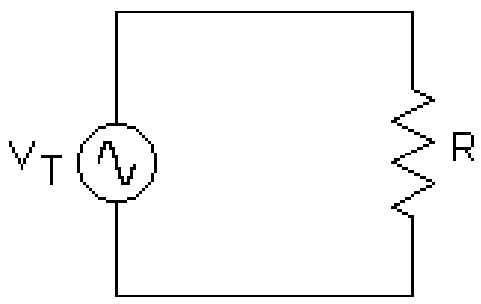

AC Power Waveform

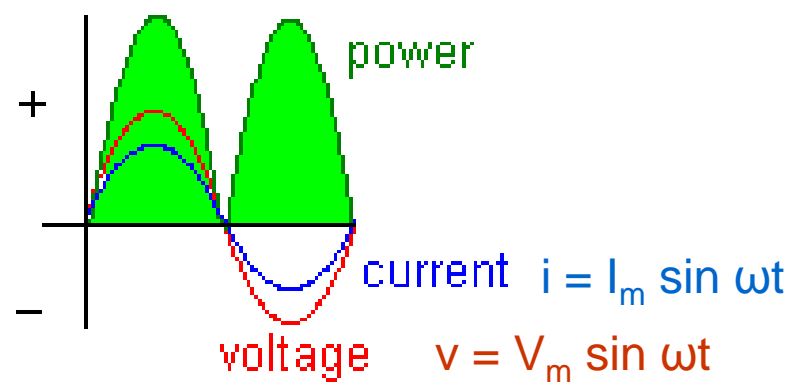

Power $P = V I$

Both V and I are RMS values

Power is positive in both half cycles

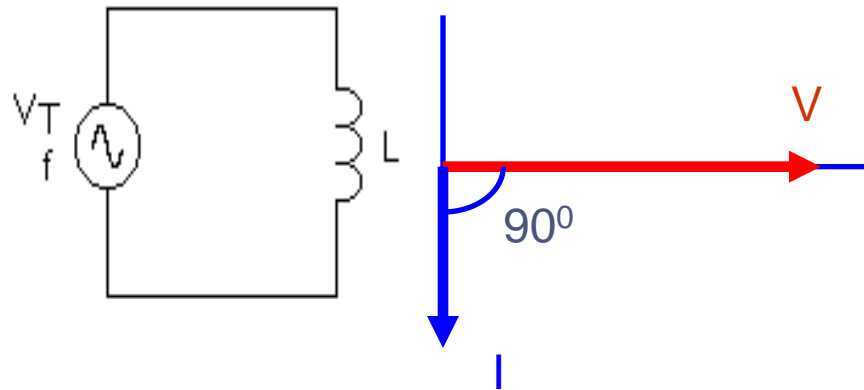

AC Power Waveform

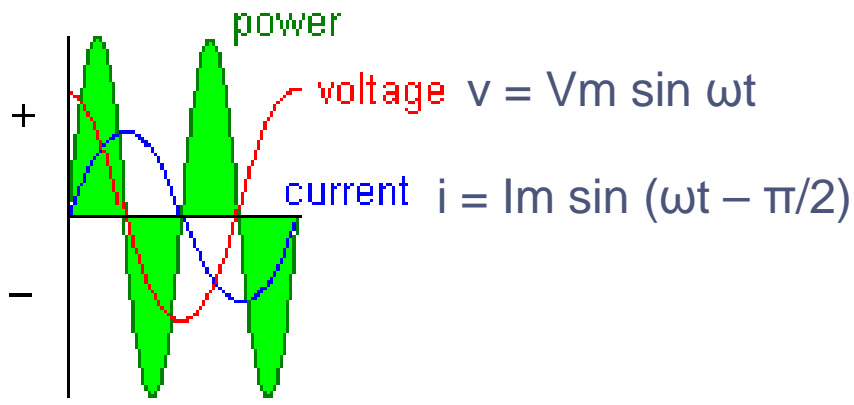

Power $P = v i$

$$= - \frac{V_m I_m}{2} \sin 2 \omega t$$

The shaded areas in this diagram show how **power** is absorbed and returned to the circuit.

The shaded areas above the baseline (+ levels) represent **power that is absorbed** by the inductor.

The shaded areas below the baseline (- levels) represent **power that is returned** to the circuit.

P (over the cycle) = 0

CAPACITIVE CIRCUIT

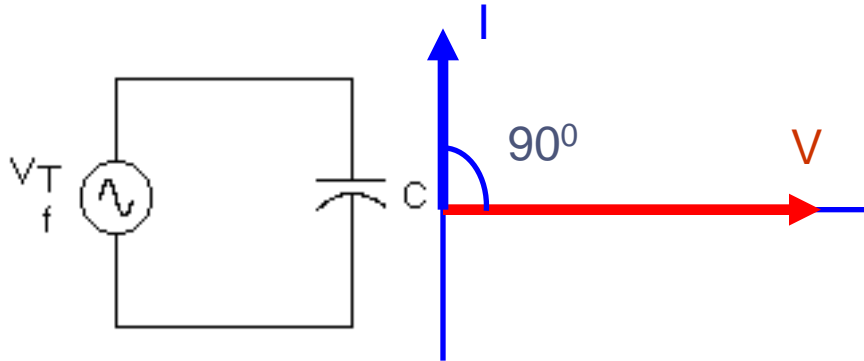

Power $P = v i$

$$= \frac{V_m I_m}{2} \sin 2 \omega t$$

The shaded areas in this diagram show how **power** is absorbed and returned to the circuit.

The shaded areas above the baseline (+ levels) represent **power that is absorbed** by the inductor.

The shaded areas below the baseline (- levels) represent **power that is returned** to the circuit.

$P = 0$

AC Power Waveform

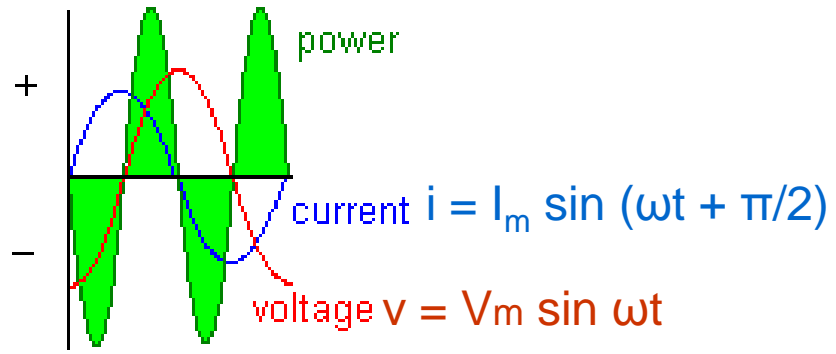

R-L circuit

Expression for a sinusoidal voltage source:

$$v = V_m \sin \omega t$$

For a *linear* circuit, in the steady state, the current is also sinusoidal and can be expressed as:

$$i = I_m \sin (\omega t - \theta)$$

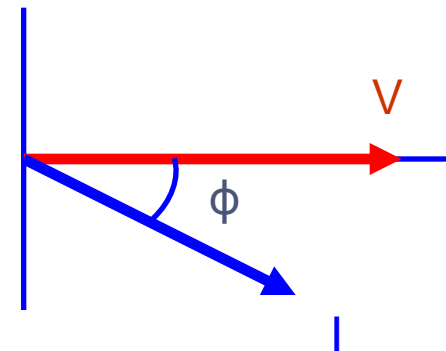
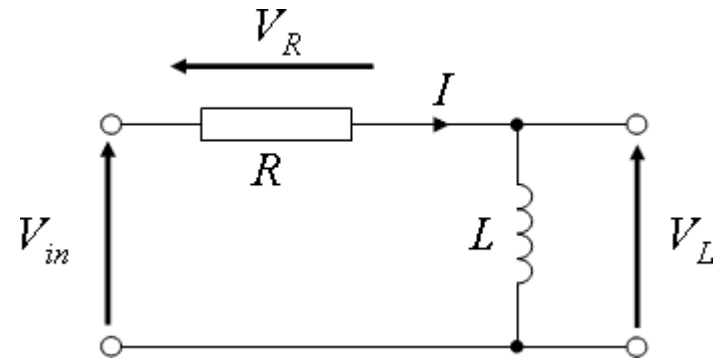

Φ Is the phase difference.

$$I \angle \Phi = I \cos \Phi + j I \sin \Phi$$

$$Z \angle \phi = R + j \omega L$$

$$Z = \sqrt{R^2 + \omega^2 L^2}$$

$$\phi = \tan^{-1} \frac{\omega L}{R}$$

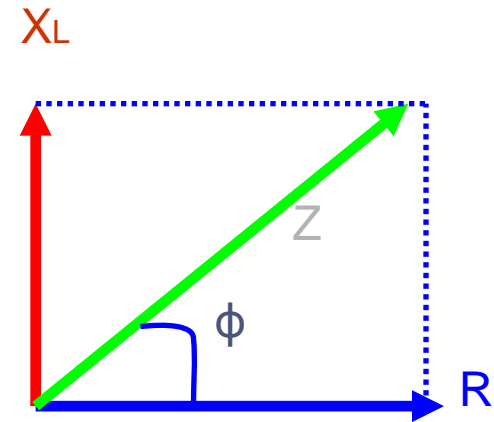

Impedance Triangle

$$P_{av} = VI \cos \phi = I^2 Z \cos \phi = I^2 R$$

Thus, all the power consumed in the R-L circuit is actually the power dissipated in the resistance

Phase Relationship: pure resistive element: $Impedance = R \angle 0^\circ$

The voltage and current phasors are in phase.

pure Inductive element:

$$Impedance = \omega L \angle 90^\circ$$

the current lags the voltage by 90°

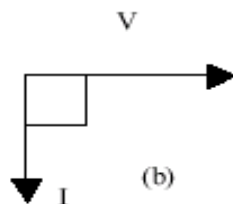
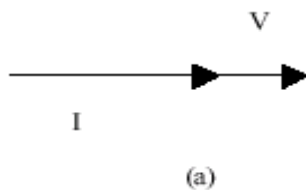

pure Capacitive element:

$$Impedance = \frac{1}{\omega C} \angle -90^\circ$$

the current leads the voltage by 90°

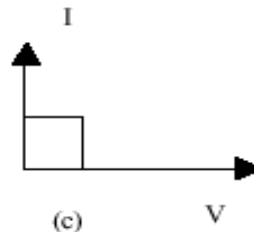

Phasor diagram for (a) resistive (b) inductive and (c) capacitive elements

Power Factor

The *power factor* in the circuit is a factor by which $V.I$ (*Apparent Power*) should be multiplied to get the Active (or real) power

$$\cos\phi = \frac{P}{S} = \frac{\text{Active Power}}{\text{Apparent Power}}$$

By convention, it is assumed, that if the circuit is inductive, the reactive power is positive, and for capacitive circuit, the reactive power is negative.

Three Types of Power

Type	Formula	Unit
Apparent	VI	volt-ampere or VA
Active	$VI \cos \phi$	watt or W
Reactive	$VI \sin \phi$	reactive volt-ampere or VAR

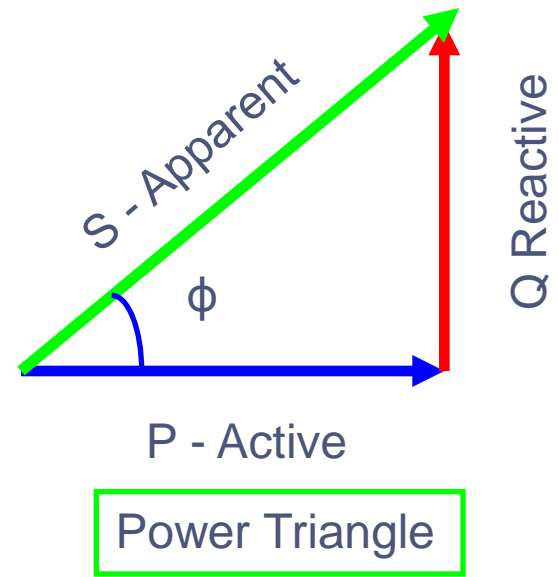
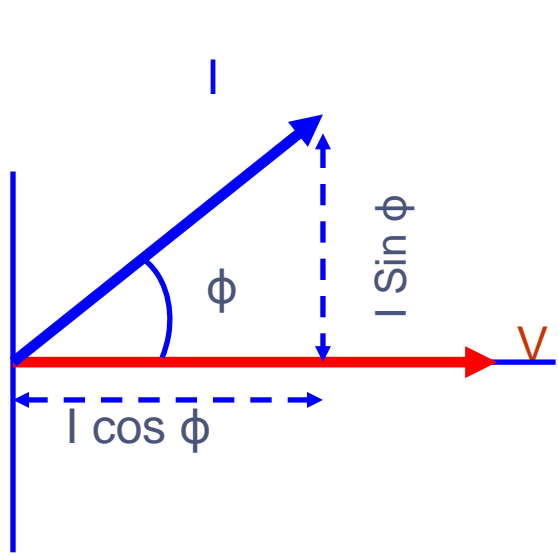

Reactive Power

The reactive power is the power that travels back and forth between the supply and the circuit due to the presence of reactive elements (inductance and capacitance).

- ❖ Over a cycle, its average is zero.
- ❖ *By convention*, it is assumed, that if the circuit is
 - ❖ inductive, the reactive power is positive, and for
 - ❖ capacitive circuit, the reactive power is negative.

AC Power Waveform for pure capacitance

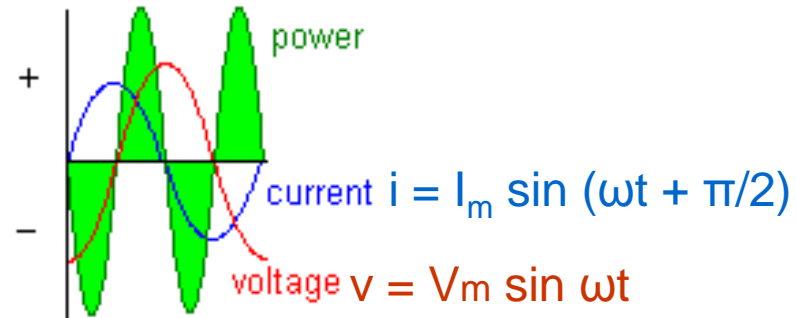



Power Flow Quadrants: IEC62053-23

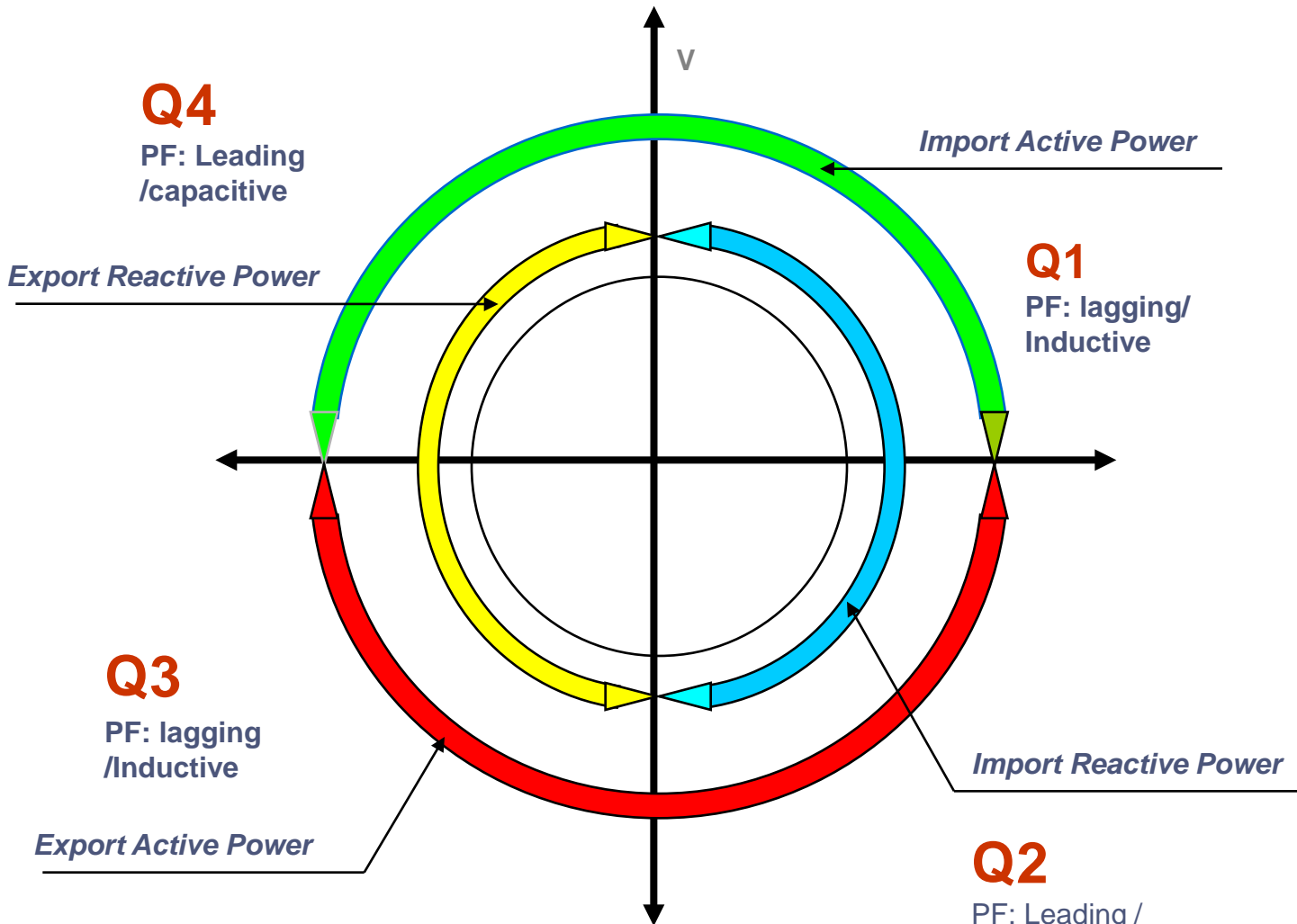

Power Flow

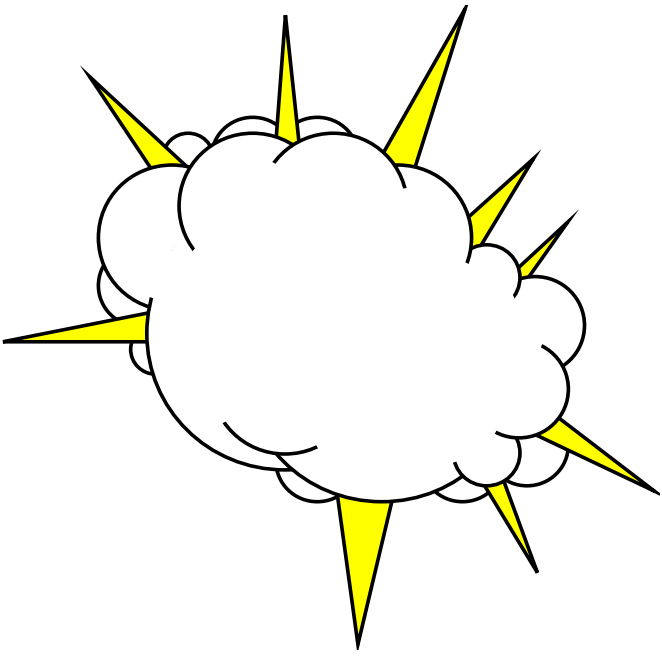

Power System

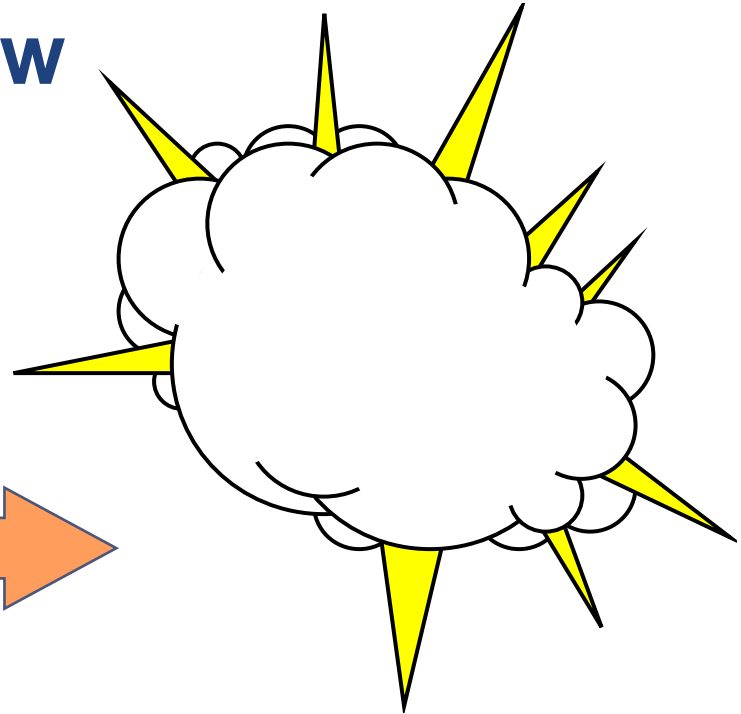
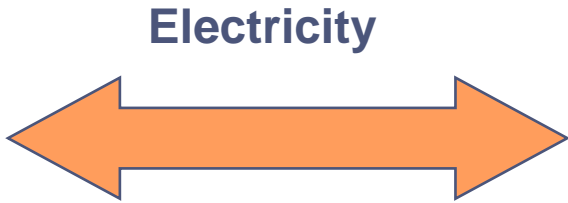

Power System

- Interconnected system of generation and load centers

Measurement Reference

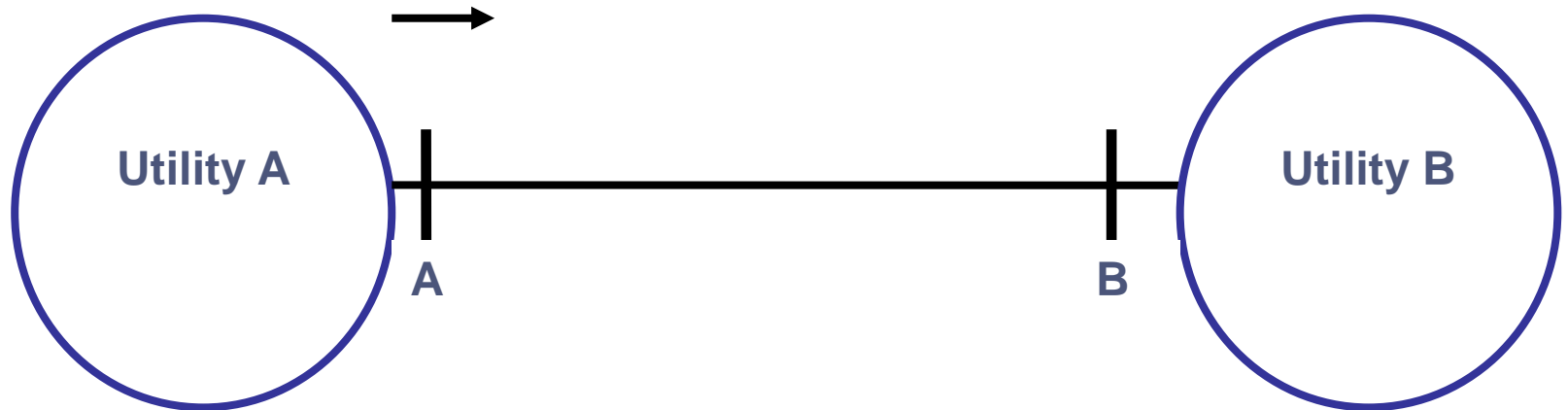

- Power flow to Voltage bus is taken positive (import)
- Current transformer connection polarity (p2 to bus side)

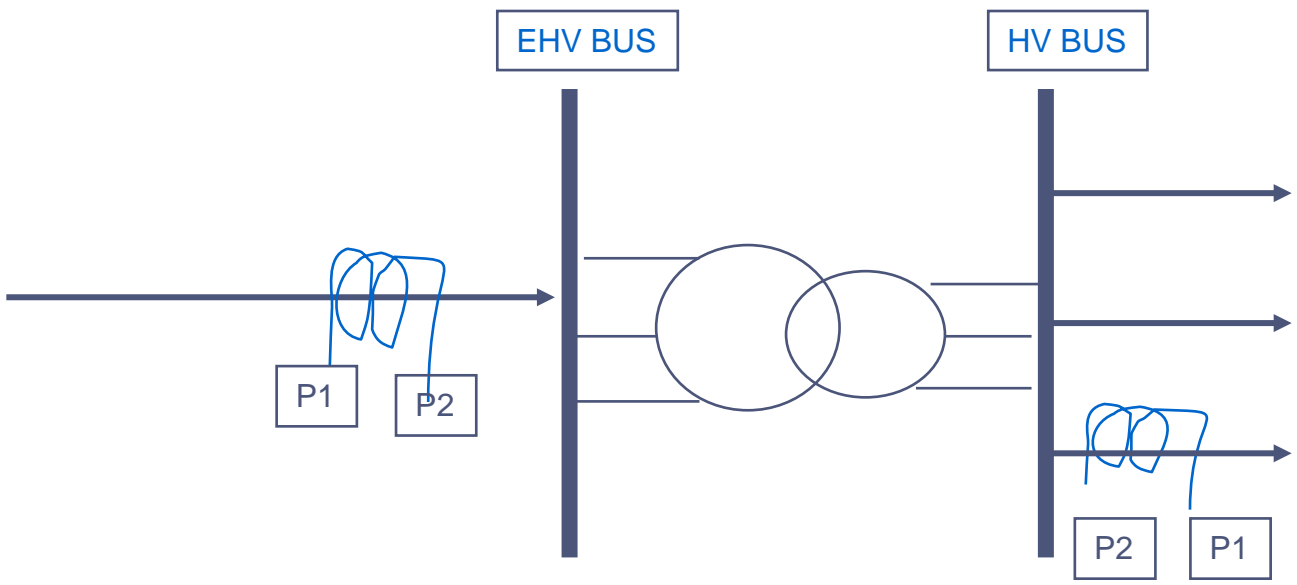

Power Components

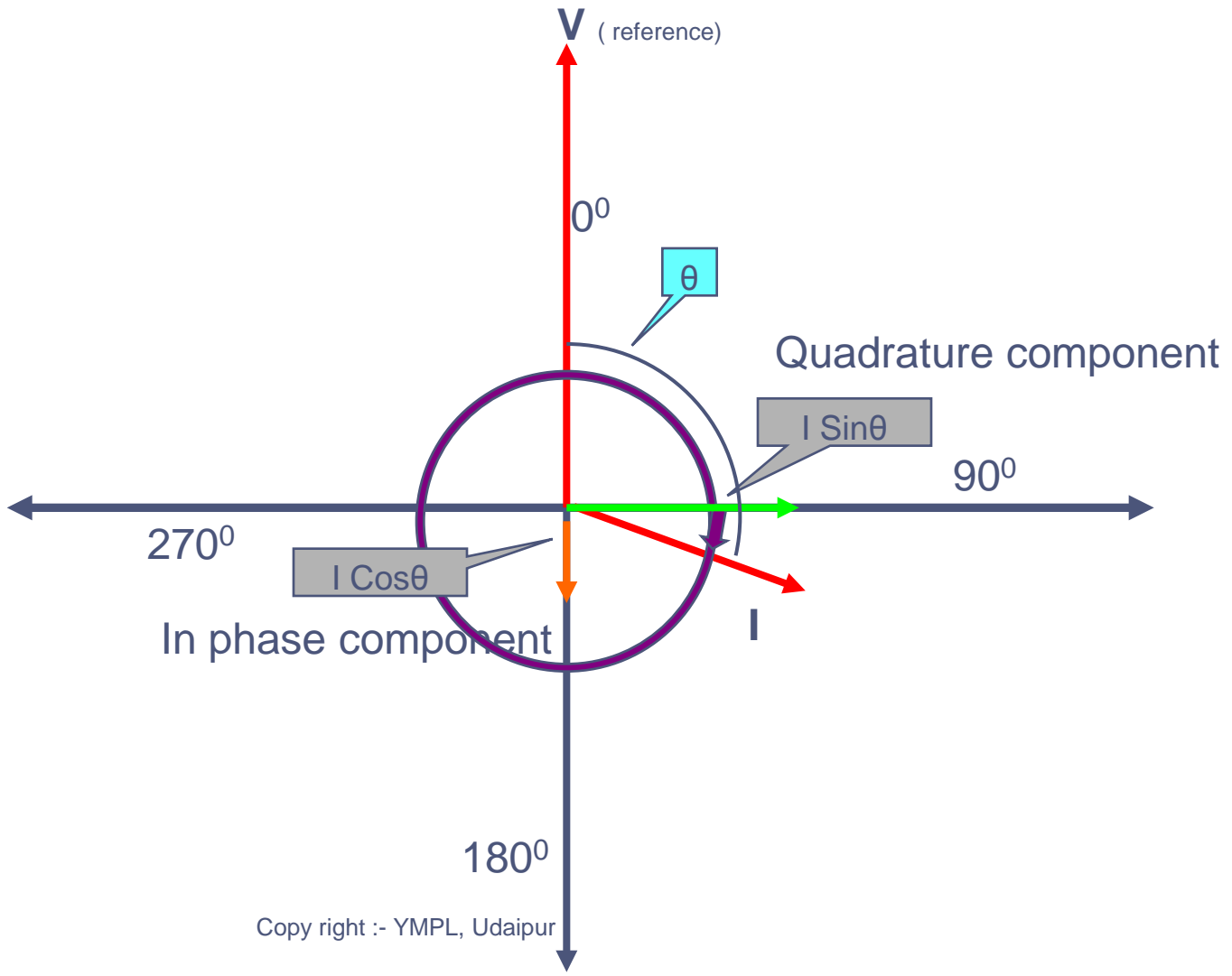

Three phase system

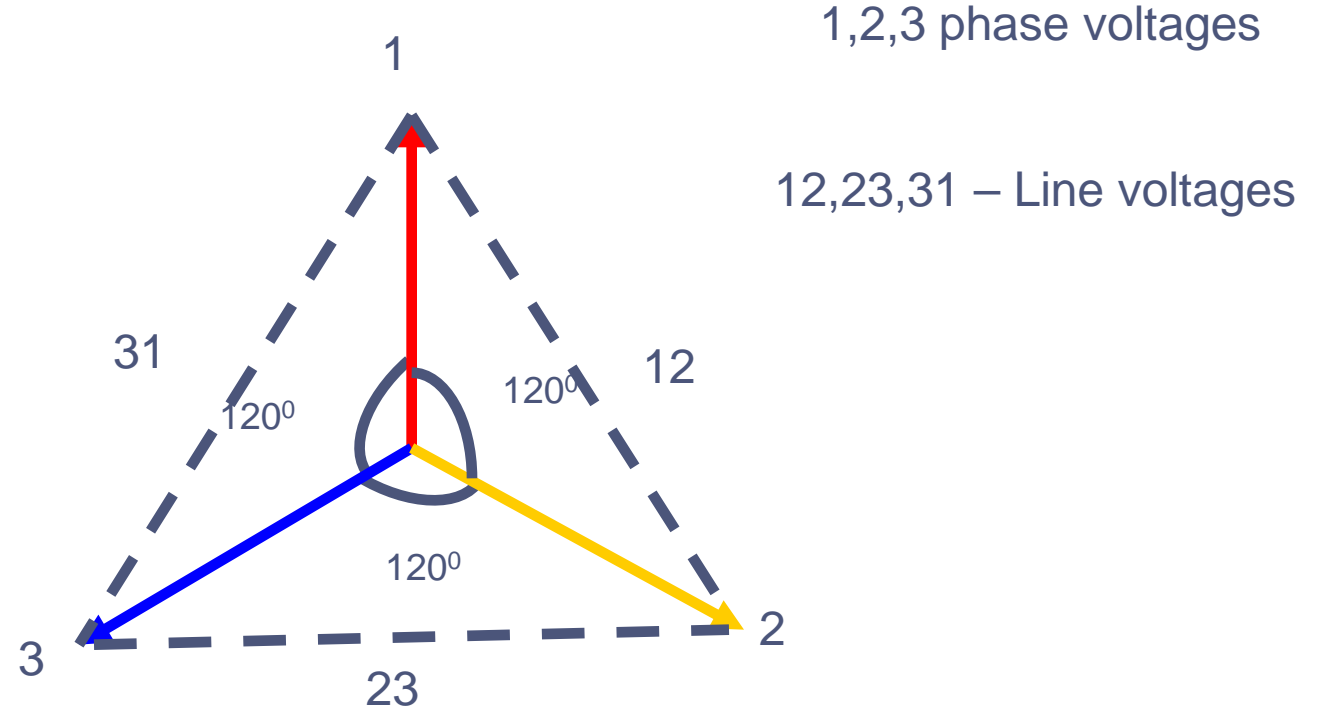

Three phase system

How to get phase voltages by Phasor additions?

1,2,3 phase voltages

$$V_{12} = V_1 - V_2 = V_1 + (-V_2)$$

12,23,31 – Line voltages

Using Law of Parallelogram

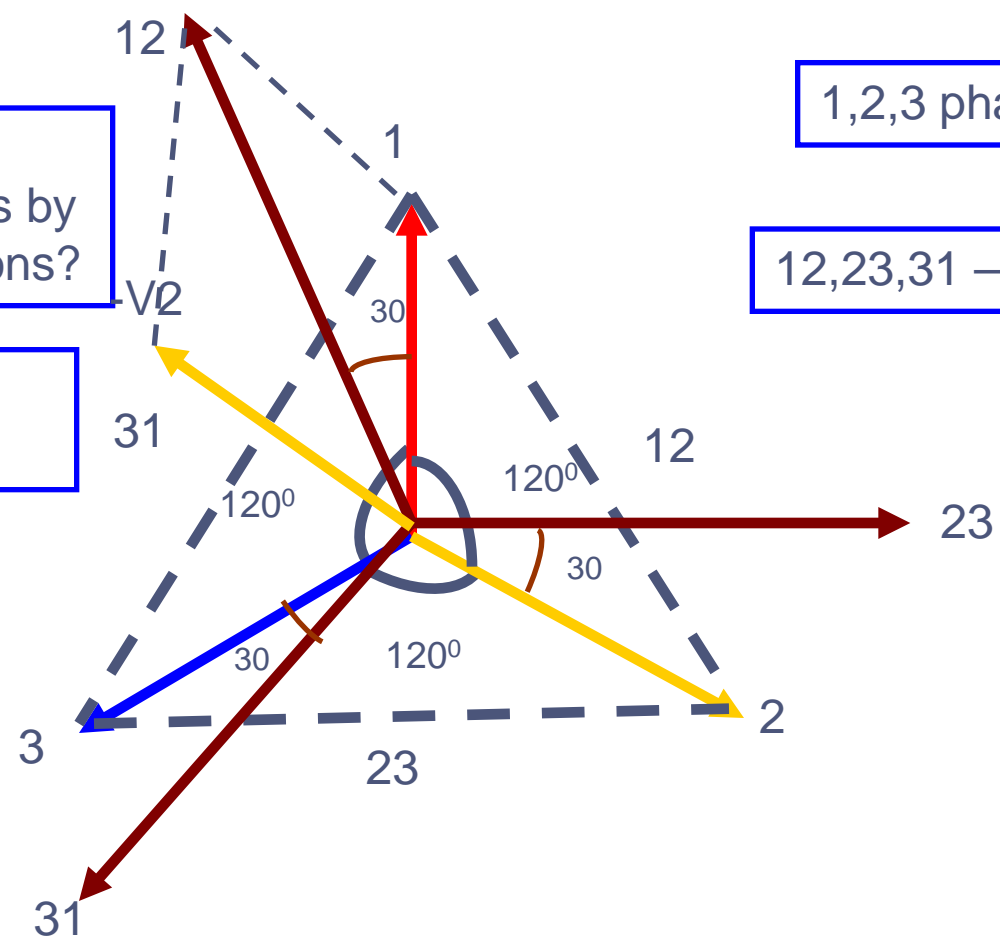



Three-phase Y configurations

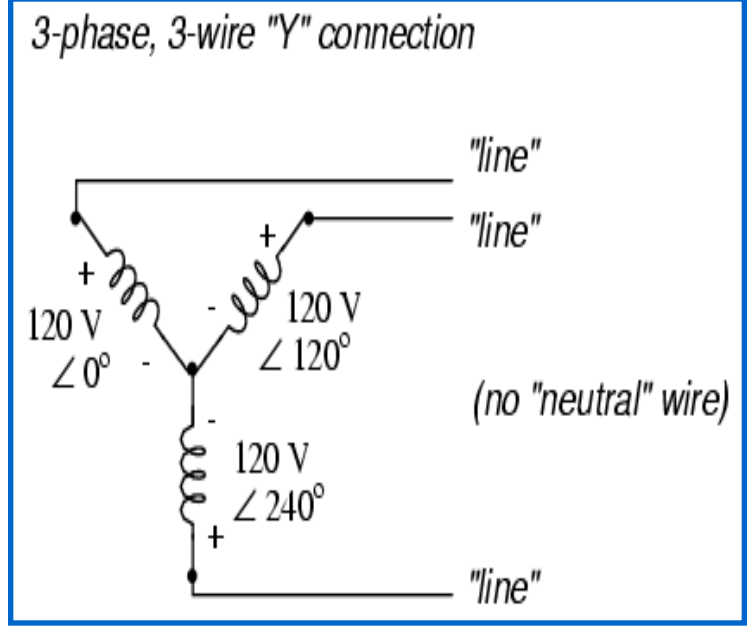
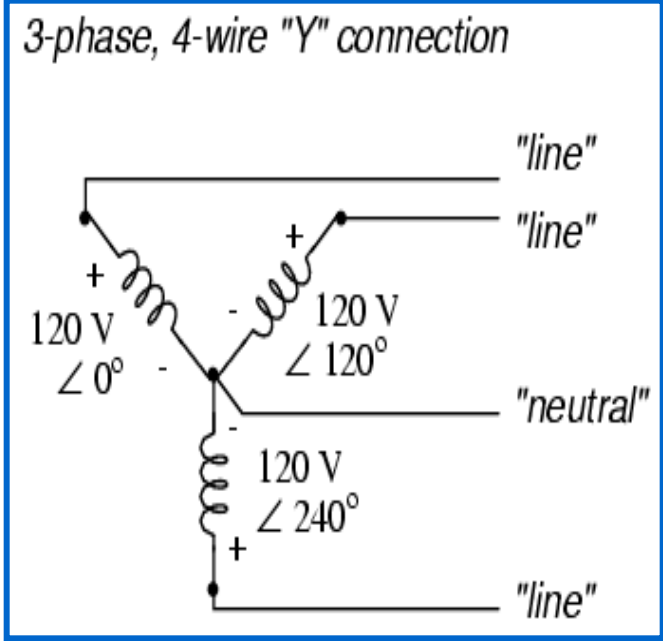

For "Y" circuits:

$$E_{line} = \sqrt{3} E_{phase}$$

$$I_{line} = I_{phase}$$

Three-phase Y and Δ configurations

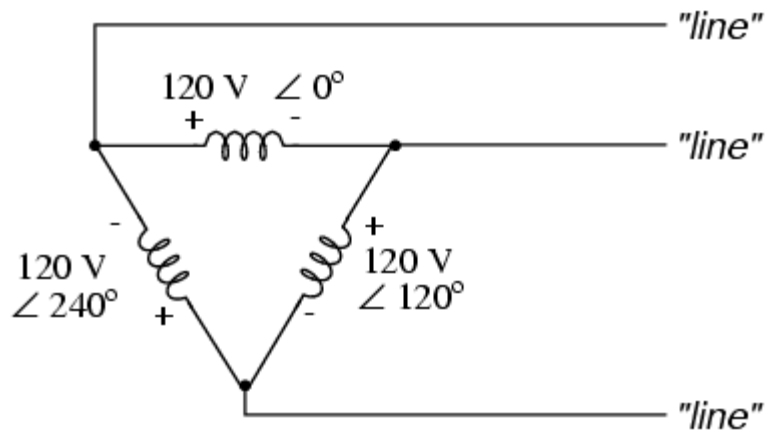

For Δ ("delta") circuits:

$$E_{line} = E_{phase}$$

$$I_{line} = \sqrt{3} I_{phase}$$

Phasor representation of a 3 phase load

- E_r, E_y, E_b voltages.
- I_r, I_y, I_b currents.
- Φ_1, Φ_2, Φ_3 phase angles (lagging)

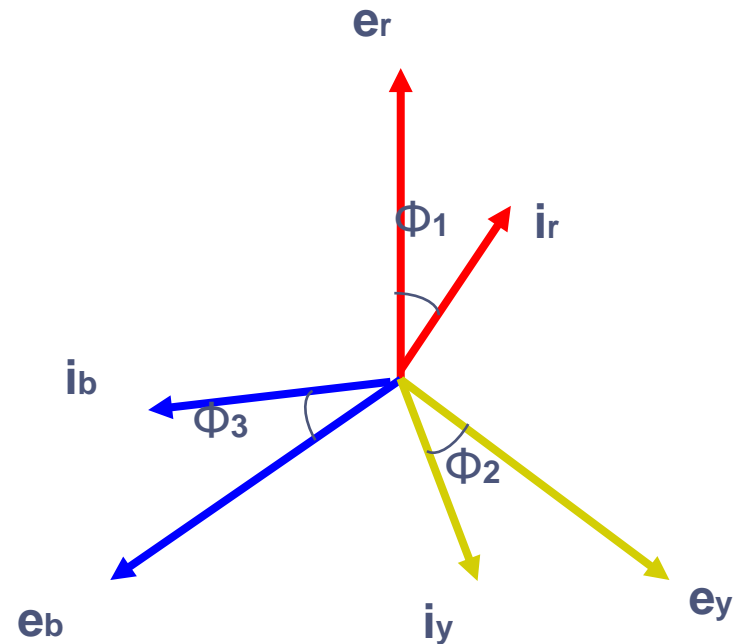

Thank you