



**USAID**  
FROM THE AMERICAN PEOPLE

SARI / Energy

***Yadav Measurements Pvt. Ltd.***

***Instrument Transformers***  
***By: Kiran Kelapure***

A specifically designed programme for

Da Afghanistan Breshna Sherkat (DABS)  
Afghanistan



# Electricity Metering technologies and systems

## Areas Covered Under this Module

1. Understand importance of instrument transformers in revenue metering.
2. Voltage and Current transformers (Types, Definitions, Testing methods).
3. Standards applicable

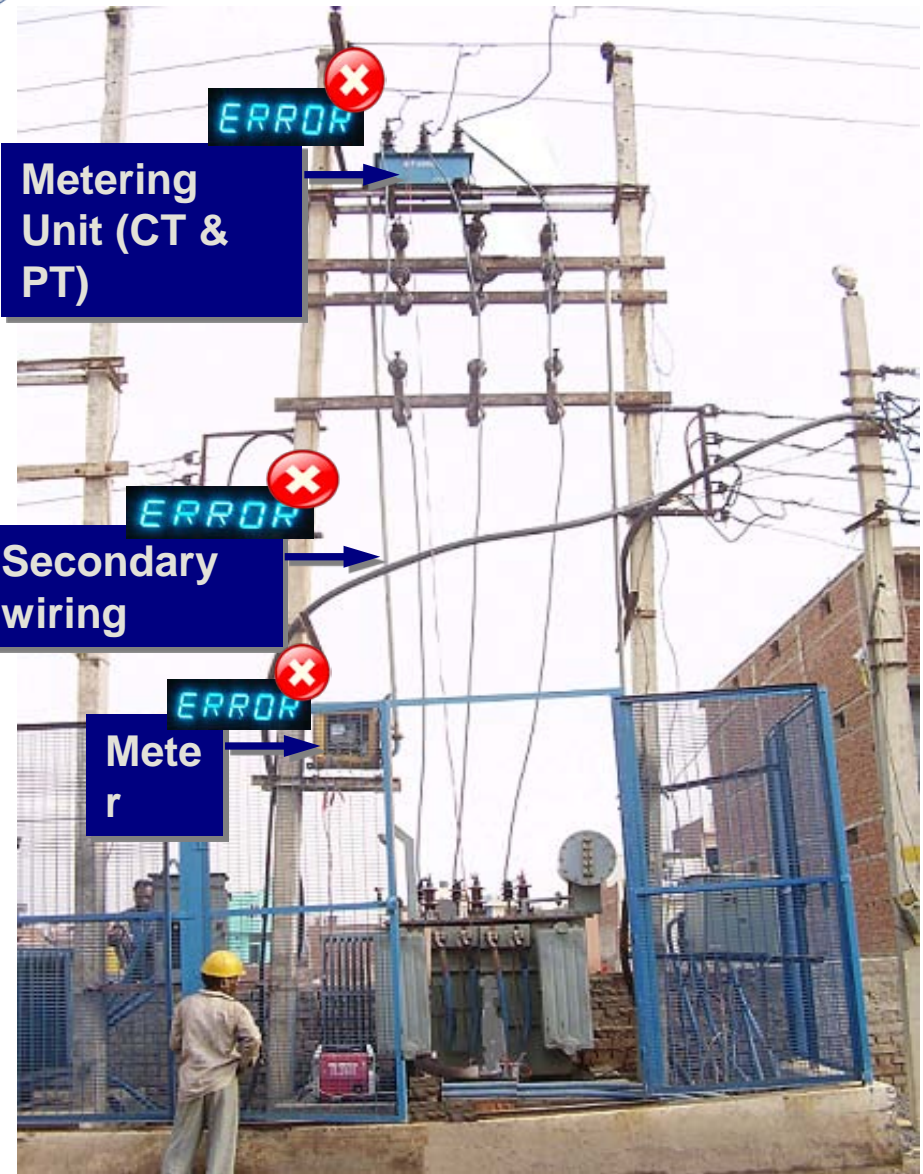

**Sources of errors**

**Typical setup at HT customers**

## Importance

- Metering system accuracy is governed by instrument transformers, if used in LT CT or HT CT/VT systems. ( HT3 or HT 4)
- All errors add algebraically.

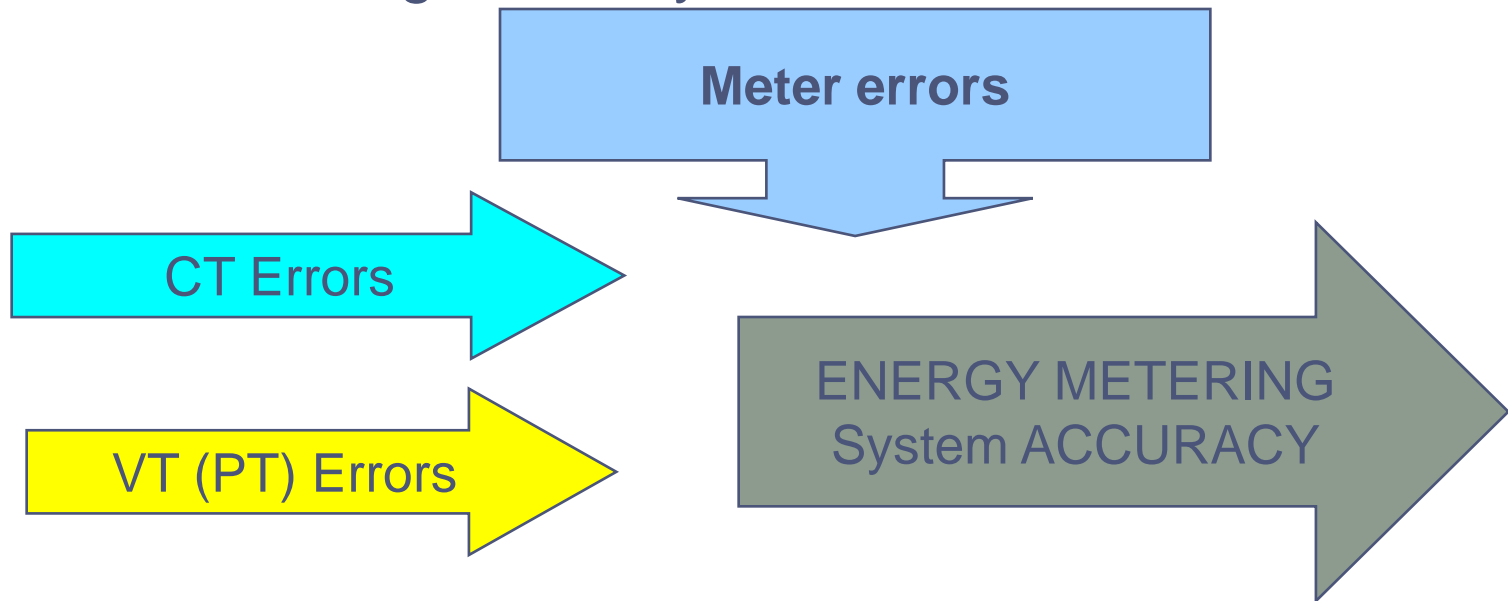

# Importance

- Meters may be of high accuracy, but are instruments transformers too?,  
generally not, may be one class lower.



**USAID**  
FROM THE AMERICAN PEOPLE

SARI / Energy

*Let us view process of  
Error drifting in CT / PT*

# Error Drifting

It may saturate the Core of the CT

Fault Current will pass through Metering CT



Over a period the CT Error may drift



# Error Drifting

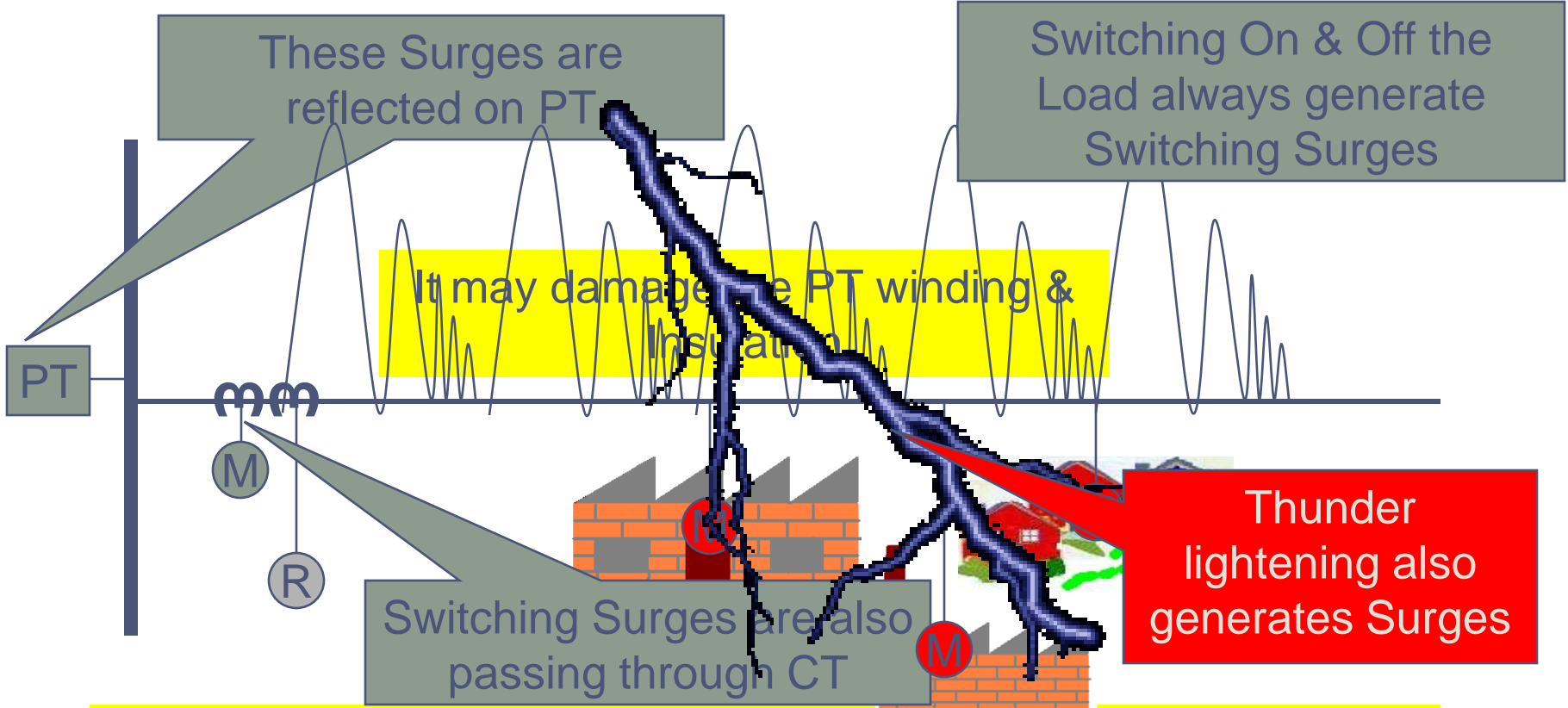

- Over a period the PT Error may drift
- Over a period the CT Error may drift
- Over a period the CT/PT may develop inter turn short
- Over a period, the wiring may get damaged

# Error Drifting

## To Summarise

Accuracy of instrument transformers do change due to

- Aging
- Environmental effects like ambient temperature, temperature cycling , humidity etc
- line transients and surges leading to insulation leakage, shorted turns
- fault currents leading to saturation of cores,

## Other Factors

- Higher ratio CTs when used at lower loads, may have large errors as they may operate at lower % load.
- With static meters burden being low, if higher burden CT/PT are used, their performance at lower burden is questionable, as not even specified by standards.
- Drop across leads in VTs, depending on burden connected.
- If a PT or CT is used for indication only, then ratio errors are important, phase error doesn't matter.

## Instrument transformers

- Voltage transformers
- Current transformers
- Combined CT/PT units or metering Units

## Instrument transformers

- A transformer intended to supply input to measuring instruments, meters, relays and other similar apparatus.
- These provide isolation and a measurable (standardized) signal at safe voltage levels.
- Safety of persons and equipments which are interfaced

# Current Transformers

## Current transformer

- An instrument transformer in which the secondary current, in normal conditions of use is substantially proportional to the primary current and differs in phase from it by an angle which is approximately zero for an appropriate direction of the connections.

## Types of CTs... by application

- **Measuring current transformer**

A current transformer intended to supply indicating instruments, integrating meters and similar apparatus.

- **Protective current transformer**

A current transformer intended to supply protective relays and similar apparatus.

## Types of CTs.... by construction

- **Window type or ring type current transformer**

A current transformer having no primary winding as an integral part of the structure. This current transformer has an opening in the center to accommodate a primary conductor through it.

- **Wound-primary current transformer**

A current transformer in which the primary winding consists of a single turn loop or multi-turn coil integral with the transformer.

- **Bar-primary current transformer**

A current transformer in which the primary winding consists of a bar of suitable size and material forming an integral part of the current transformer the primary conductor is the equivalent of a single primary turn.

## Types of CTs.... by construction

- **Multiple secondary current transformer**

A current transformer having more than one secondary winding on a common core. One secondary winding is closed, other unused secondary should be left open circuit and not closed or short circuited.

- **Multiple-primary current transformer**

A current transformer having more than one primary winding on a common core.

- **Multiple ratio current transformer**

A current transformer from which more than one transformation ratio can be obtained by the use of taps on the primary or secondary windings or both, or by series / parallel connection of separate primary or secondary windings on a common core, or by other means.



## Types of CTs.. .....by insulation

- Tape wound CTs: these are ring type CTs, with polyester or fiber glass tape .
- Resin cast CTs: these are ring type CTs, with polyester or PVC tape and then cast into resin. Resin works as insulation as well as provides environmental protection. Terminals and supporting clamps are also cast in the resin.
- Oil filled CTS: these are generally HT type of CTS. In these, oil is used as insulation and provides cooling also.



## Types of CTs... by application

- **Interposing current transformer**

A current transformer which is intended to amend the ratio of a main current transformer by having its primary winding connected to secondary winding of the main current transformer and its secondary winding connections to the burden.

- **Summation current transformer**

A current transformer which is intended to summate the currents in a number of feeders in association with the feeder current transformer

- **Core balance current transformers.**

The core balance current transformers are intended for providing earth leakage protection on 3 phase electrical system.

## Some definitions

- **Rated primary current:**  
The value of primary current which appear in the designation or rating plate and on which CT performance is based. The value of current which is to be transformed to a lower value. In CT parlance, the "load" of the CT refers to the primary current.
- **Rated secondary current:**  
The current in the secondary circuit and on which the performance of the CT is based. Typical values of secondary current are 1 A or 5 A.
- **Rated burden:**  
The apparent power of the secondary circuit in Volt-amperes expressed at the rated secondary current and at a specific power factor (0.8 for almost all standards)

## Some definitions .... Contd.

- **Accuracy class:**

In the case of metering CT s, accuracy class is typically, 0.2, 0.5, 1 or 3. This means that the errors have to be within the limits specified in the standards for that particular accuracy class. The metering CT has to be accurate from 5% to 120% of the rated primary current, at 25% and 100% of the rated burden at the specified power factor.



## Some definitions .... Contd.

- **Short time rating:**

The value of primary current (in kA) that the CT should be able to withstand both thermally and dynamically without damage to the windings, with the secondary circuit being short-circuited. The time specified is usually 1 or 3 seconds.

- **Instrument security factor (factor of security):**

This typically takes a value of less than 5 or less than 10 though it could be much higher if the ratio is very low. If the factor of security of the CT is 5, it means that the composite error of the metering CT at 5 times the rated primary current is equal to or greater than 10%. This means that heavy currents on the primary are not passed on to the secondary circuit and instruments are therefore protected. In the case of double ratio CT's, FS is applicable for the lowest ratio only.

## CT errors ( Ratio error )

- The error which a transformer introduces into the measurement of a current and which arises from the fact that the actual transformation ratio is not equal to the rated transformation ratio.
- The current ratio error expressed in percent is given by the formula.

$$\text{CURRENT ERROR \%} = \frac{(K_n I_s - I_p) \times 100}{I_p}$$

Where

$K_n$  = the rated transformation ratio

$I_p$  = the actual primary current

$I_s$  = the actual secondary current when

## Phase displacement or error

- The difference in phase between the primary and secondary current vectors, the direction of the vectors being so chosen that the angle is zero for a perfect transformer.
- The phase displacement is said to be positive when the secondary current vector leads the primary current vector.

(this definition is correct for sinusoidal currents)

## Some facts about CTs...

- CT is a variable flux device, unlike PT , which is a constant flux device.
- CT secondary shall never be open circuited, when primary is energised, it produces very high voltages, which may be fatal, as well cause damage to equipments.

## Some facts about CTs

- **CTs may saturate due to**
  - Open secondary winding.
  - Due to DC current in secondary, like for testing resistance using a multi-meter.
  - Due to short circuit fault
- **Due to saturated core**, ratio and Phase errors increases on negative side
- Such CTs shall be demagnetised.

## Testing of current transformers

- *Comparison Method:* or Primary injection method: This is a modification of the basic bridge methods. Instead of reading the primary and secondary currents, the secondary current of a calibrated 'standard' / reference current transformer and the transformer undergoing test are compared with each other by nulling method using a bridge , or direct error computation. The comparison method , of course requires the use of a 'Standard' current transformer with a rating which corresponds to that of each current transformer involved in calibrating.
- We require a source, reference CT, calibrated burden set, and a comparator.
- Reference temp specified is 40 deg C

## PRINCIPLE OF OPERATION CURRENT TRANSFORMER CALIBRATION

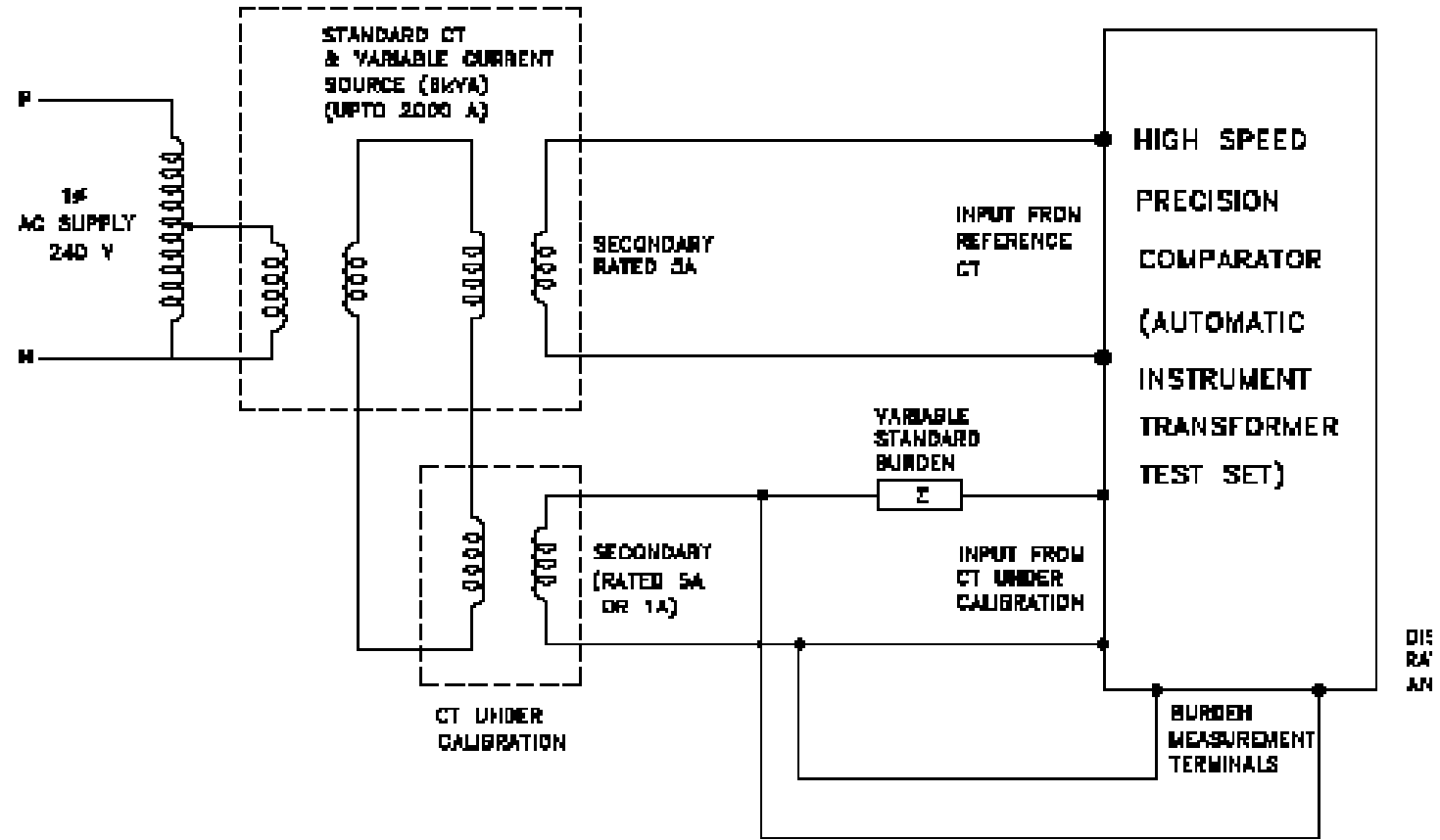



# CT Performance For Class 0.5

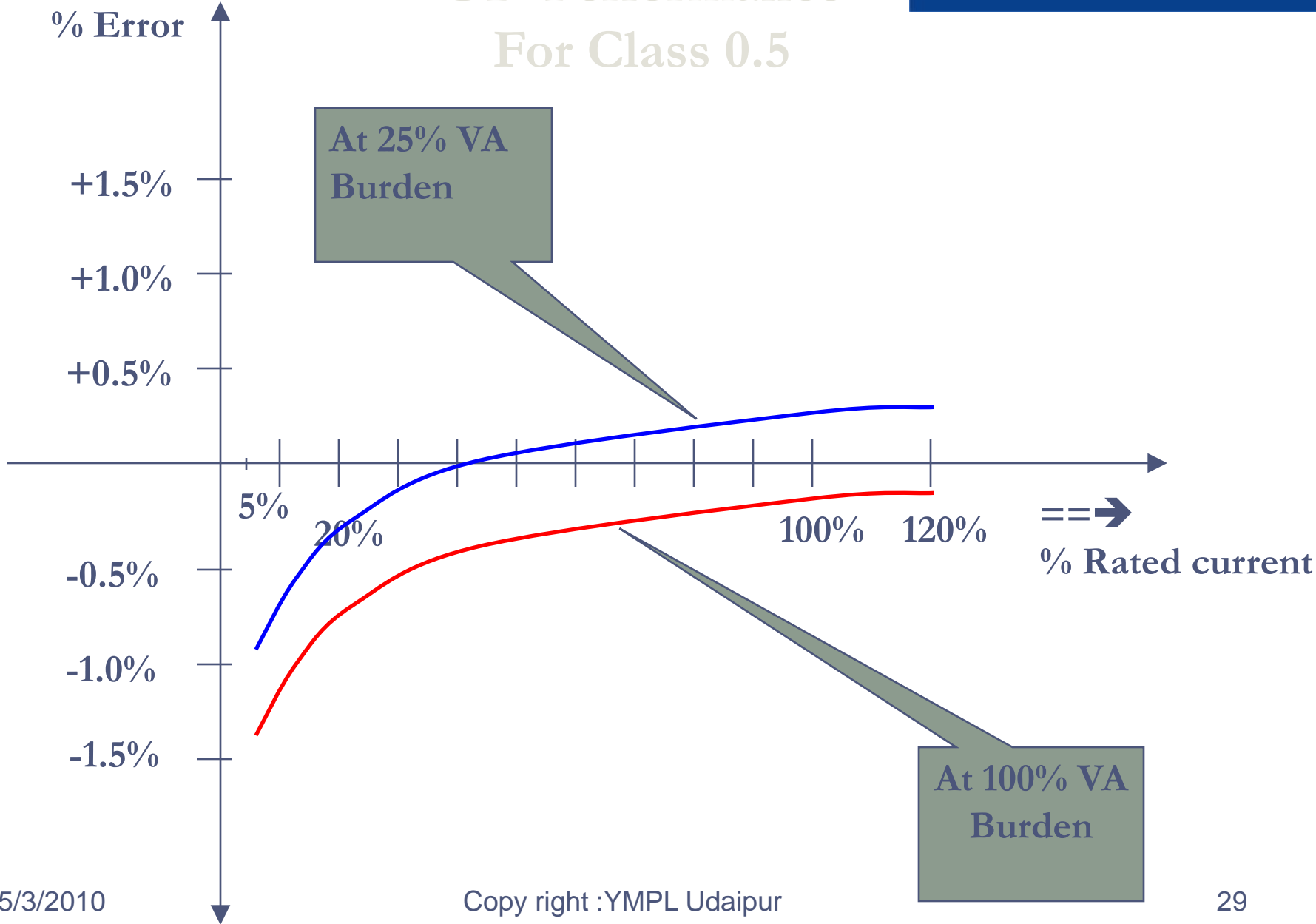

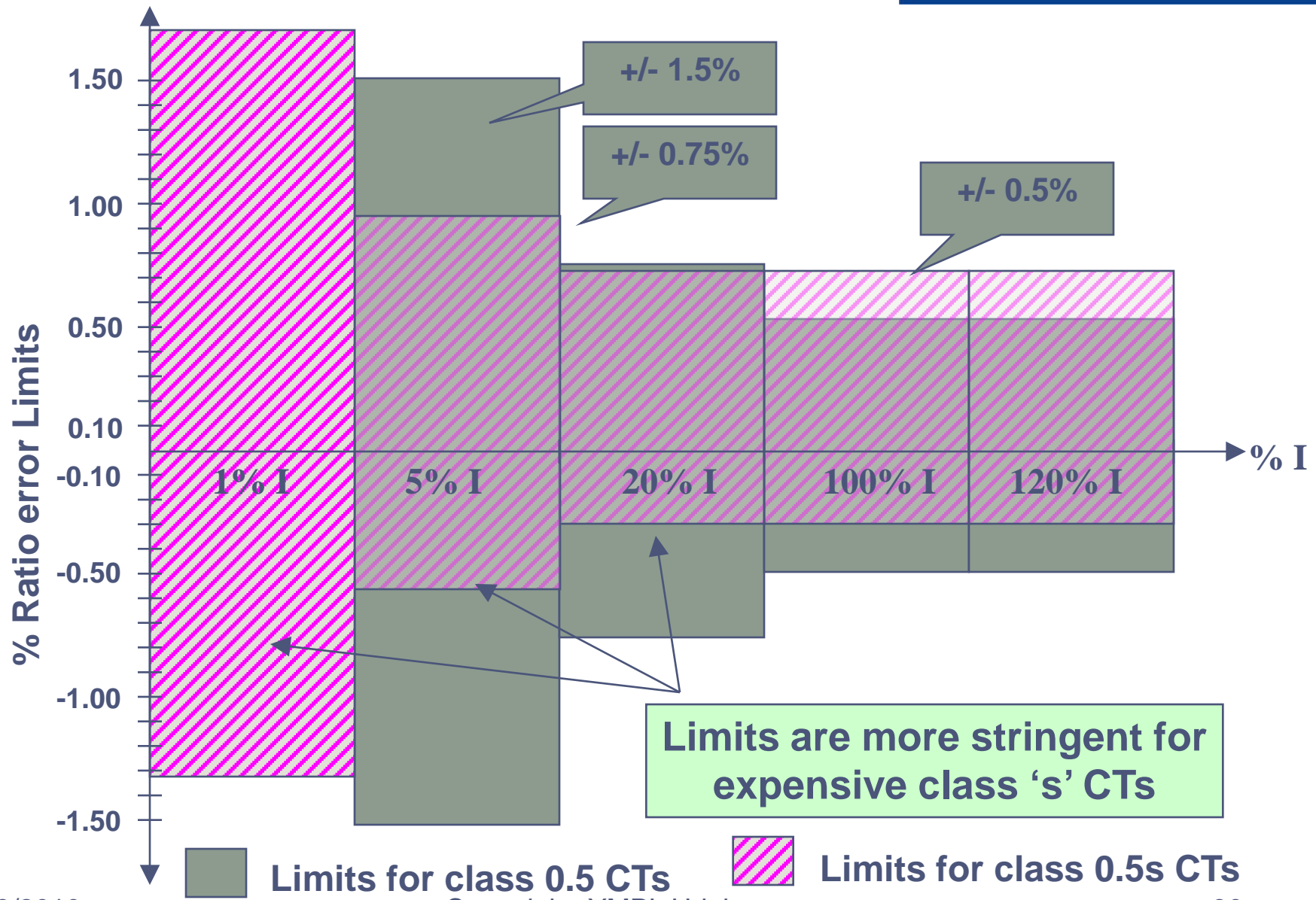

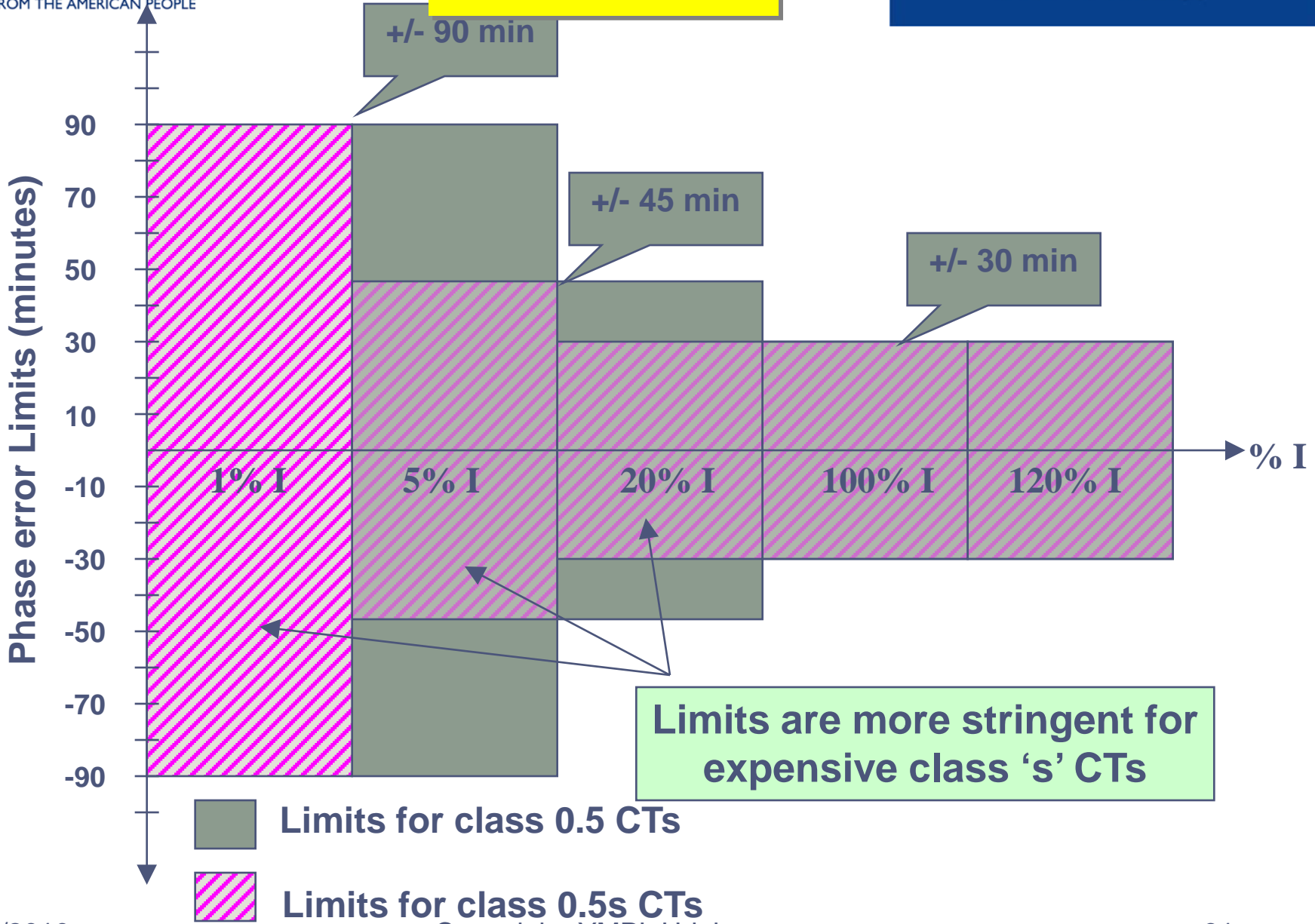

# Limits of errors.

**AS PER IS 2705/1992 AND IEC 60044.1/1996.**

ACCURACY CLASS	+ % CURRENT (RATIO) ERROR AT % of RATED CURRENT.				PHASE DISPLACEMENT IN MINUTES % OF RATED CURRENT			
	5	20	100	120	5	20	100	120
0.1	0.4	0.2	0.1	0.1	15	8	5	5
0.2	0.75	0.35	0.2	0.2	30	15	10	10
0.5	1.5	0.75	0.5	0.5	90	45	30	30
1.0	3.0	1.5	1.0	1.0	180	90	60	60

# Voltage Transformers

## Voltage transformer

- An instrument transformer in which, in normal conditions of use and for an appropriate direction of the connections.
  - Secondary voltage, is substantially proportional to the primary voltage.
  - Differs in phase from it by an angle which is approximately zero

## Electromagnetic voltage transformer

- A voltage transformer which transforms the primary voltage to the secondary voltage entirely by electromagnetic phenomena.

## Capacitor voltage transformer

- A voltage transformer comprising a capacitor divider unit and an electromagnetic unit so designed and interconnected that the secondary voltage of the electromagnetic unit is substantially proportional to and in phase with the primary voltage applied to the capacitor divider unit.

## Definitions

- **Rated Primary Voltage / Secondary Voltages**

The rms values of the voltage upon which the performance of the voltage transformer is based.

- **Rated Transformation Ratio**

The ratio of the rated primary voltage to the rated secondary voltage.

- **Normal System Voltage**

The rms line-to-line voltage by which the system is designated.



## Errors in VTs, definitions

### Voltage error (ratio error)

- Introduces into the measurement of a voltage and which arises when the actual transformation ratio is not equal to the rated transformation ratio.
- The voltage error, expressed in percent, is given by the formula :

$$\text{VOLTAGE ERROR} = \frac{k_n \cdot U_s - U_p}{U_p} \times 100\%$$

### Where

**$k_n$  = The rated transformation ratio,**

**$U_s$  = The actual secondary voltage, when  $U_p$**

**is applied under the conditions of measurement, and**

**$U_p$  = The actual primary voltage**

# Errors in VTs, definitions

## Phase errors

- The difference in phase between the primary voltage and the secondary voltage vectors, the direction of the vectors being so chosen that the angle is zero for a perfect transformer.
- This phase displacement is said to be positive when the secondary voltage vector leads the primary voltage vector and negative when it lags. It is usually expressed in minutes.

( definition is strictly correct for sinusoidal voltage only.)

## Rated insulation level

That combination of voltage values which characterized the insulation of a transformer with regard to its capability to withstand dielectric stresses .

- Eg.: 12 / 28 / 75 KVp

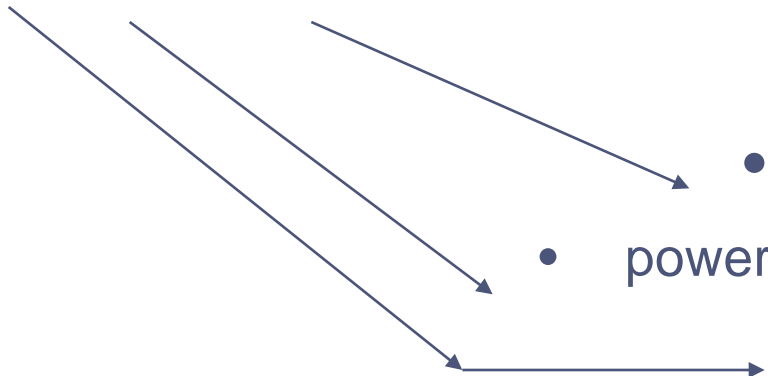
- 
- Impulse withstand voltage
  - power frequency withstand voltage
  - Highest system voltage

## Voltage Transformer construction

- Basic elements of construction of voltage transformer are
  - **Magnetic circuit (core)**
  - **Electrical circuit i.e. Primary and secondary windings**
  - **Insulation, basic and additional**
  - **Housing and other mechanical details**
  - **Terminals and mounting arrangements**
  - **Earthing facility.**

## Voltage Transformer construction

- Potential transformer consists of two separate windings on a common magnetic steel core. One winding consist of relatively large number of turns of fine wire, called primary winding. The other winding consists of fewer turns of heavier wire and is called secondary winding.
- The core material used is generally, GOSS.
- Sec. winding is made of thicker wire, with tight coupling between primary and secondary windings. These help to keep resistances of coils as well as leakage inductance low. Which in turn help to keep errors low.
- Suitable insulation between primary and secondary and to the body is maintained.

## Voltage transformer design

- The VT normally works on a constant magnetic flux density.
- Never short circuit the secondary terminals of a potential transformer. A secondary short circuit will cause the unit to over heat and fail in a very short period of time.
- For protection, there may be fuses in Primary or secondary or both.
- For reasons of tamper, these days fuses are not used.

## Testing a VT

- Many methods, like voltmeter, with standard PTs, resistor or capacitor dividers with voltmeters.
- *Comparison Method*: This is a modification of the basic ‘potentiometer’ method. Instead of reading the primary and secondary voltages, the secondary voltage of a calibrated ‘standard’ transformer and the transformer undergoing test are compared with each other by nulling method using a bridge , or direct error computation. The comparison method , of course requires the use of a ‘Standard ‘ potential transformer with a rating which corresponds to that of each potential transformer involved in calibrating.
- Reference temp specified is 40 deg C

**PRINCIPLE OF OPERATION  
POTENTIAL TRANSFORMER CALIBRATION USING LABORATORY SOURCE  
(3.3 kV – 33 kV)**

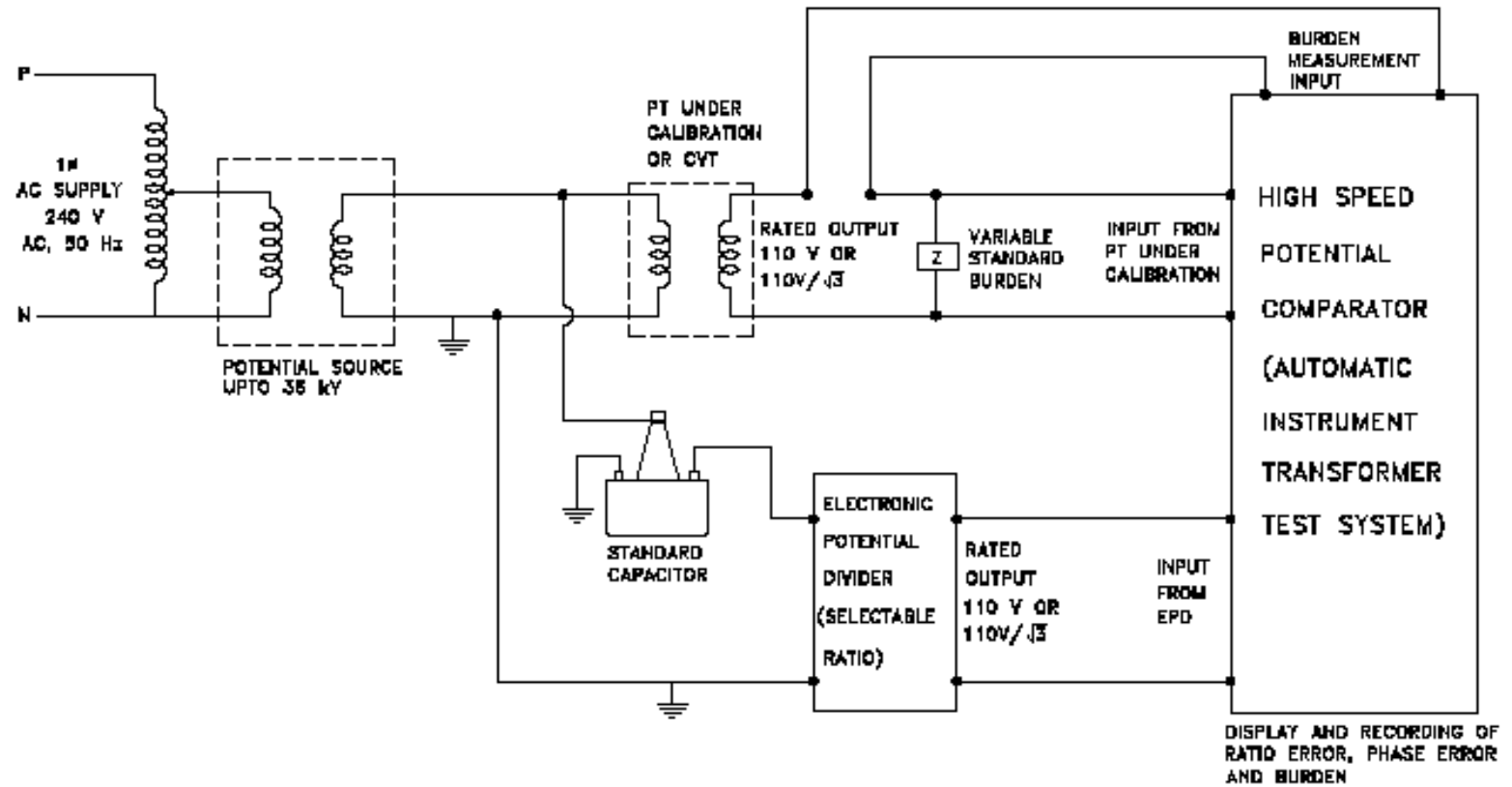



**LIMITS OF VOLTAGE ERRORS AND PHASE DISPLACEMENT AS PER  
IS 3156 / 1992 & IEC 60044-2 / 1997**

<b>CLASS</b>	<b>PERCENTAGE VOLTAGE (RATIO) ERROR</b>	<b>PHASE DISPLACEMENT (MINUTES)</b>
0.1	+/-0.1%	+/- 5
0.2	+/- 0.2%	+/- 10
0.5	+/- 0.5%	+/- 20
1.0	+/- 1.0%	+/- 40
3.0	+/- 3.0%	Not specified

Effect of load power factor on phase error

<b>PF</b>	<b>Angle in Deg</b>	<b>error in Min</b>	<b>error in Deg</b>	<b>Effective angle</b>	<b>Effective PF</b>	<b>% error</b>
<b>0.5</b>	<b>60</b>	<b>1</b>	<b>0.0166667</b>	<b>59.98333333</b>	<b>0.50025</b>	<b>0.050</b>
<b>0.6</b>	<b>53.1301</b>	<b>1</b>	<b>0.0166667</b>	<b>53.11343569</b>	<b>0.60023</b>	<b>0.039</b>
<b>0.7</b>	<b>45.573</b>	<b>1</b>	<b>0.0166667</b>	<b>45.55632933</b>	<b>0.70021</b>	<b>0.030</b>
<b>0.8</b>	<b>36.8699</b>	<b>1</b>	<b>0.0166667</b>	<b>36.85323098</b>	<b>0.80017</b>	<b>0.022</b>
<b>0.9</b>	<b>25.84193</b>	<b>1</b>	<b>0.0166667</b>	<b>25.8252661</b>	<b>0.90013</b>	<b>0.014</b>
<b>0.95</b>	<b>18.19487</b>	<b>1</b>	<b>0.0166667</b>	<b>18.1782057</b>	<b>0.95009</b>	<b>0.00956</b>

THANK YOU