



ENERGY EFFICIENT LIGHTING

Prof Dr. Shahidul I. Khan

Director,

Centre for Energy Studies,

Bangladesh University of Engineering and Technology

Dhaka 1000, Bangladesh.

E-mail: shahidul@eee.buet.ac.bd



LIGHTING CONSUMPTION

- Lighting consumes about 30% of total electrical energy used in Bangladesh.
- 41% electricity is used for lighting by commercial & residential consumers and 5% by industrial consumers.
- Incandescent and fluorescent lights are mostly used.
- Estimated 1 crore 11 lakh incandescent lamp and Fluorescent lights are in service.
- Energy efficient lights are costly.



LIGHTING CONSUMPTION

- Industries where lumen requirement is very high should use Energy Efficient Lights (EEL).
- Electronic ballast for fluorescent light is double the price of conventional magnetic ballast but the energy consumption about 25%.



COMPARISON OF LIGHT SOURCES

Type	LumenPer watt	Life X 1000 Hours	Relative efficiency based on HPS	Start-up-time (minute)	Lumen maintenance	Colour Rendition	Operating Cost
Incandescent	15-25	0.75-12	19%	Immediate	Fair to Excellent	Excellent	High
Florescent	55-85	7.5-24	65%	Immediate	Fair to Excellent	Good to Excellent	Average
Compact Fluorescent Light(CFL)	45-60	10	46%	Immediate	Good	Good	Low
LED Lights	70-120	50-100	92%	Immediate	Very Good	Good	Very Low
Mercury Vapor	50-60	16-24	46%	2-7	Very Good	Poor to Excellent	Average
Metal Halide	80-100	1.5-15	77%	2-5	Good	Very Good	Below Average
High Pressure Sodium (HPS)	75-130	20-24	100%	3-4	Excellent	Good	Low



EFFECTS OF FITTINGS AND FIXTURES

- Shade is a very important factor in lighting. It controls the illuminated area.
- The luminous flux from a light source is never emitted uniformly.
- The characteristic of light source and fittings are shown in Figures.



LUMINOUS INTENSITY DIAGRAM

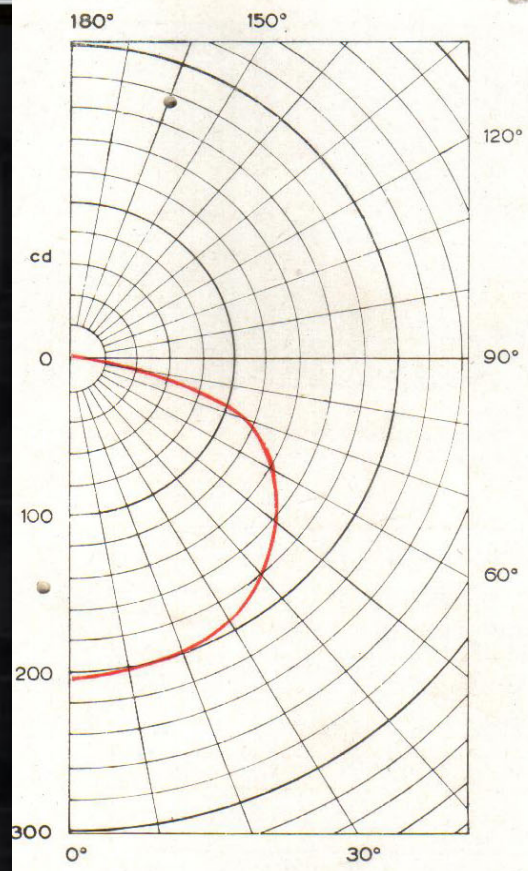



LUMINOUS INTENSITY DIAGRAM

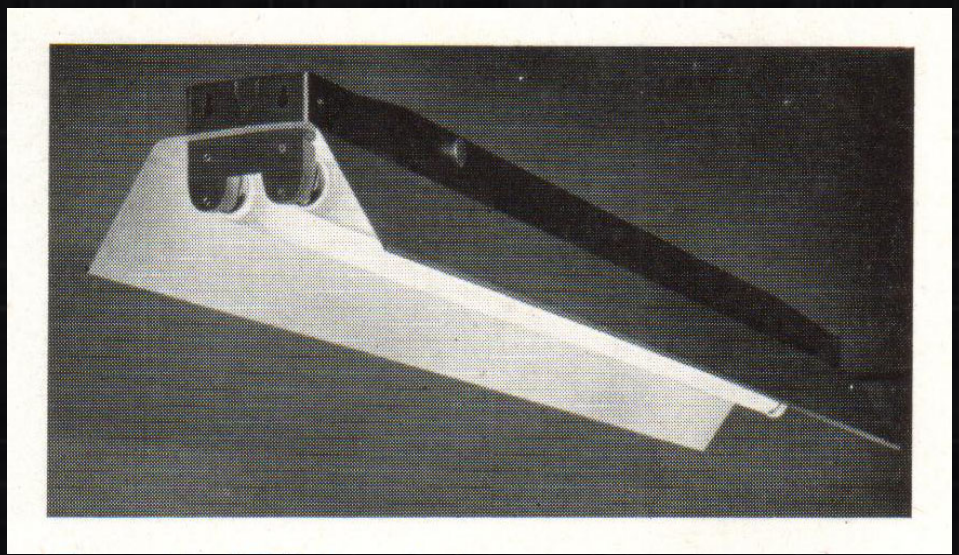
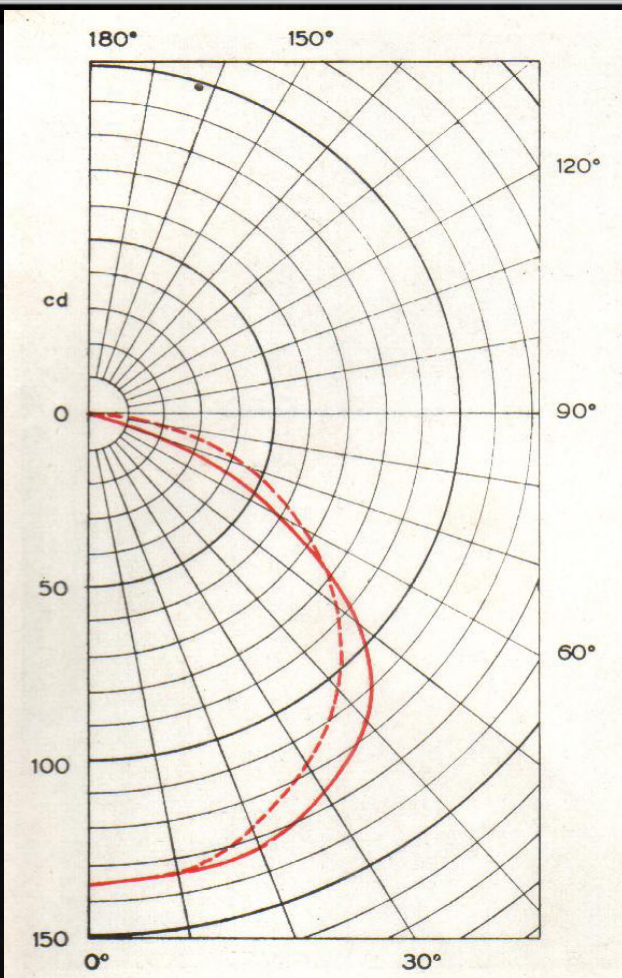



EFFICACY AND EFFICIENCY

- Lamp Efficacy =
$$\frac{\text{Apparent Brightness (lumen)}}{\text{Electrical Power (watts)}}$$

$$\frac{\text{Total Power Radiated (watts)}}{\text{Electrical Power (watts)}}$$
- Lamp Efficiency =
$$\frac{\text{Total Power Radiated (watts)}}{\text{Electrical Power (watts)}}$$
- Illumination: The incident luminous flux per unit of area.
Unit: lux (lx); 1 lux = 1 lumen / m²
Symbol: *E*.



VARIOUS TERMS AND DEFINITIONS RELATED TO ILLUMINATION LEVELS

Illumination at a point:

The illumination at a point is equal to the luminous intensity divided by the square of the distance of the source of the light to the point in question.

$$E_p = I / r^2$$

In which E_p = illumination at the point p in lux
 I = the luminous intensity in candela
 r = distance from the light source to the area in m.

Or

$$\text{Lux}_p = \text{candela} / \text{m}^2$$

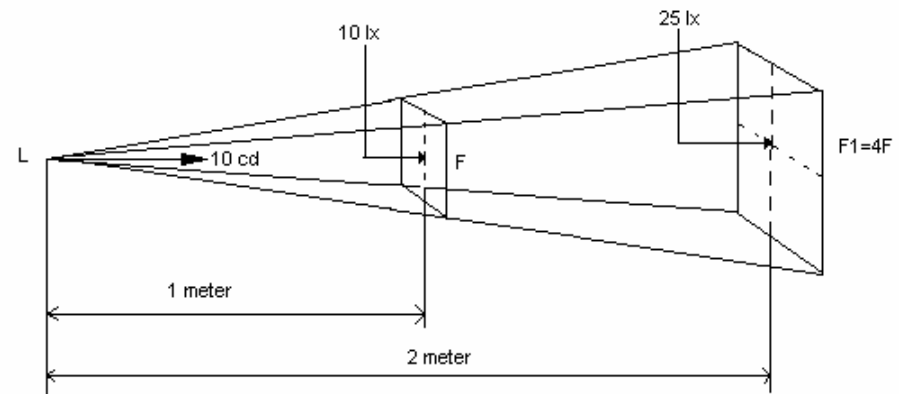



DIFFERENT TYPES OF LIGHTS

There are different types of lights used for home, industrial, sports, decoration, architectural lighting, etc.

From January 1, 2001 all lamps for domestic use must carry an energy level indicating energy efficiency class on a scale of A (very efficient) to G (inefficient).

Types Of Lighting:

- ✓ Incandescent Light
- ✓ Fluorescent Light
- ✓ CFL
- ✓ HID Light
- ✓ LED Light



FLUORESCENT LIGHTS



- Fluorescent lamps are extensively used in industries.
- There are two types of FL are available in the market 40 W and 36 W with the same lumen output. There is a saving of 4 W per tube. Electronic ballast could also save some watt.



ENERGY EFFICIENT LIGHTS

Compact Fluorescent Light (CFL) is an energy efficient light. Its benefits are 80% savings in electricity costs compared with incandescent lamps of same brightness, and up to 15 times the life of incandescent lamps.

But the main problem is price. It is about 13 times costlier than incandescent lamp in local market.



PROBLEMS OF INTRODUCTION OF CFL

- If we try to replace 1,11,00,000 bulbs by CFL, it will require a large amount.
- Moreover, it is quite difficult to convince all users at a time. They will be reluctant to bear the cost.
- Technical Problems:
 - Electronic circuit is sensitive to spike and voltage fluctuation
 - System Power Quality must be good for full life expectancy



SOLUTION



- The bulbs will be replaced step by step. Almost 10% i.e. 11,00,000 will be collected by distribution companies.
- A subscriber will collect a CFL and pay its cost in 12 installments with the electric bill
- There must be some sort of incentive. If government does not levy taxes on EEL, then the price will be within the reach of many people. If 10% of all GLS could be changed to EEL, then load reduction is over 42.12 MW ($1080 \times 10^6 \times 0.1 \times 0.65 \times 0.60 = 42.12$ MW, D.F.=0.65, 2004-05 data used).



LED LIGHT



- Light Emitting Diode is a semiconductor diode
- Emits light when DC flows
- Bright white LED used for lighting purpose
- Lumen / Watt and lifetime – Extremely high
- AC LED is in experimental stage



CASE STUDIES



Use of Energy Efficient Lights

Industries where lumen requirement is very high should use Energy Efficient Lights (EEL). Although the initial cost is very high, but during its life time savings is over 50%. In domestic sector the initial cost may be high when compared to middle class people's income.

Replacement of magnetic ballast by electronic ballast saves energy about 25%

Retrofit

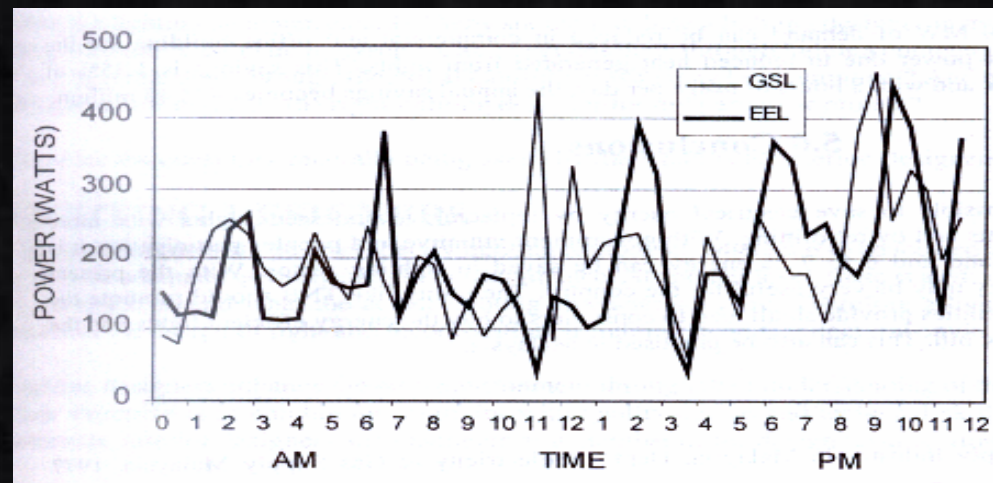



ILLUMINATION SOCIETY



There is an illumination society called Illumination Society of Bangladesh (ISB), which works for disseminating the knowledge of illumination engineering to bulb manufacturer, light fixture industries and lighting engineers. ISB is a member of World Illumination Society.



NATURAL LIGHT



An alternative source of light could be natural light. Some industries need large floor space with medium intensity of lumen per square. Natural light could be integrated in the architectural design of such factory building.



USE OF NATURAL LIGHT



- Figure shows a KLIA, Malaysia. Natural is integrated in airport lighting .Natural is integrated in airport lighting in Tribhuban International Airport, Kathmandu, Nepal and Kuala Lumpur International Airport (KLIA), Malaysia.





CONCLUSION



This lecture discussed the various methods of energy saving measures in lighting sector for home and industries. Some of the measures may be cost effective and suitable. In depth cost analysis and socio-economic condition should be studied before they are implemented.

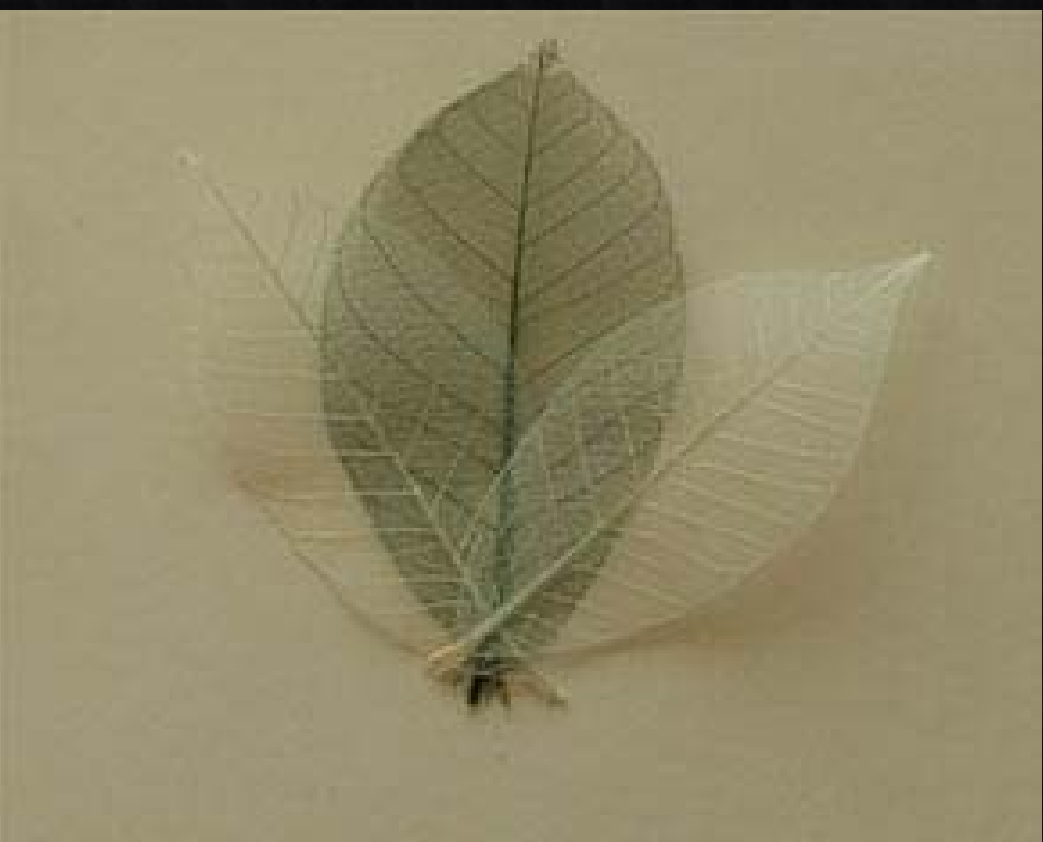

**Thank
You**